CS 552 Computer Networks

Fall 2008

Rich Martin

Course Description

- Graduate course on computer networking
 - Undergraduate knowledge of networking assumed
 - Packets, routing (DV, link-state), layering and encapsulation, protocol stacks, congestion control ...
- Goals:
 - Learn about computer networking research
 - Gain skills needed to perform research
 - Problem selection
 - Solution and research methodologies
 - Presentation, “marketing”

Overview

- Administrative
- Course Topics
- Overview and history of the Internet
- A Taxonomy of Communication Networks

Administrative

- Instructor: Richard Martin
- TA: Begumhan Turgut
- Course web page:
<http://www.cs.rutgers.edu/~rmartin/teaching/fall08/cs552/>
- Check web page for
 - Readings, assignments, due dates, announcements

Expected work

- Readings and discussion
 - Must do 10 (short) paper reviews
- Position paper
 - Defend a position related to computer networks
- Reviews of other student's papers
- Revised position paper
- Project
 - An experimental research project

Class format

- Short lecture on readings for the week
 - 2-3 readings for the week
 - I will present some basic material + context
- Discussion
 - Strengths and weaknesses of the papers
 - E.g, readability, problem, methodologies, results, contribution, applicability.
 - Older papers: did the results stand up?

Course Topics

- Routing:
- Queuing theory and traffic analysis
- Network tomography
- Reliable transmission
- Location Based Services
- Cloud Computing
- Wireless
- Dependability
- Security
- Peer-to-Peer

Routing Paradigms

- What does a destination address mean?
 - Not all networks use “node centric” routing
- Explore networking address spaces
- Node-centric
 - packet and circuit switched
- Geometric
 - position-centric routing
- Application Data
 - Publish/subscribe routing

IP Routing

- Global Internet uses:
 - node-centric routing
 - IP address space
- How to route within this address space?
 - How to pick paths between a source and destination?
- Implications of routing choices
 - Performance, security, reliability, economics

Router Design

- Routing vs. Forwarding
 - Routing: which path
 - Forwarding: getting the packet from the input to the right output(s)
- Forwarding design has wide ranging impacts:
 - Latency, bandwidth, jitter
 - Security, tomography, billing (who pays)
- Router design internals are driven by forwarding

Network Tomography

- No central authority
 - Network built from the “bottom up”
 - A user’s data crosses many “black boxes”
- How to figure out state of the interior by observations at the edges?
 - Analysis of results of probing network

Queuing theory/traffic analysis

- How to mathematically describe data motion in computer networks?
- Probabilistic, stochastic analysis
- Queuing theory
 - Single queues
 - Interconnected queues
- Traffic analysis
 - Higher-level traffic descriptions

Reliable transmission

- Huge interconnected system
 - No central point of control!
 - No central design authority!
 - Failures, delays common
- How to insure data arrives as intended?
 - Forward error correction
 - Backward error detection/retransmission
- Sum of individual decisions has huge impact
 - Fairness, efficiency, performance

Location Based Services

- Wireless devices will cheap & mobile
- GPS in everything will access to power
- Novel opportunity to track all device positions
 - What to do with the information?
 - Scheduling, physical resource allocation, navigation
 - Privacy concerns
 - Security concerns

Cloud Computing

- Networks are fast enough to deliver computing over them
 - Vs. “just data”, e.g. FTP, bittorrent
 - Google Apps, Amazon EC2, S3, Yahoo Fireeagle
- New demands on the network
 - Reliability
 - Bandwidth
 - Security
 - Accountability, service models

Quality of Service

- Reliability is the 0th order quality metric
- Do all applications require same network performance?
 - Bandwidth? Latency? Jitter?
- Describe what is “quality”
- Networks that deliver different levels of quality

Dependability

- Old world:
 - E-mail, news, telnet, FTP
- New World:
 - E-commerce, “all daily activities”, (no network -> can't function?), emergency response?
- Robustness beyond packet loss
 - Human faults (e.g. misconfigurations)
 - Disasters (e.g. fire in Baltimore tunnel)
 - Bugs
 - Active Attacks

Security

- Old Internet: world of good guys
 - Problems due to bugs, bad algorithms
- Today: real world has bad guys
 - Hucksters (sellers), crackers, vandals, terrorists, thieves, governments ...
- How can we make the network robust to bad guys?
 - Trust, encryption, authentication, non-repudiation

Peer-to-Peer

- Biggest application in last 5 years
- Huge percentage of the traffic
- Issues in P2P systems:
 - Legal
 - Scalability
 - Search and retrieval
 - Performance
 - Reliability

Wireless

- Old internet: all machines wired
- New Internet: many wireless devices
- What are the impacts on:
 - Mobility?
 - Performance?
 - Security?
 - Economics?

Next Week

- Pick 1 paper from the list
- Right a paper review
- Email the review to the TA
 - Bturgut@cs.rutgers.edu

Paper Reviews

- More structure this year.
- In 100 words or less, describe the following:
 - Summary
 - What were the authors trying to accomplish?
 - To whom is the work relevant
 - Your opinion on the overall quality of the work
- See the class web page for an example

Break



Overview

- Administrative
- Course Topics
- Overview and history of the Internet
- A Taxonomy of Communication Networks

What is a Communication Network? (End-system Centric View)

- Network offers one basic service: move information
 - Bird, fire, messenger, truck, telegraph, telephone, Internet ...
 - Another example, transportation service: move objects
 - Horse, train, truck, airplane ...
- What distinguish different types of networks?
 - The services they provide
- What distinguish services?
 - Latency
 - Bandwidth
 - Loss rate
 - Number of end systems
 - Service interface (how to invoke the service?)
 - Others
 - Reliability, unicast vs. multicast, real-time...

What is a Communication Network? (Infrastructure Centric View)

- Communication medium: electron, photon
- Network components:
 - Links – carry bits from one place to another (or maybe multiple places): fiber, copper, satellite, ...
 - Interfaces – attach devices to links
 - Switches/routers – interconnect links: electronic/optic, crossbar/Banyan
 - Hosts – communication endpoints: workstations, PDAs, cell phones, toasters
- Protocols – rules governing communication between nodes
 - TCP/IP, ATM, MPLS, SONET, Ethernet, X.25
- Applications: Web browser, X Windows, FTP, ...

Types of Networks

- Geographical distance
 - System Area Networks (SAN): Myrinet, Infiniband
 - Local Area Networks (LAN): Ethernet, Token ring, FDDI
 - Metropolitan Area Networks (MAN): DQDB, SMDS
 - Wide Area Networks (WAN): X.25, ATM, frame relay
 - Caveat: SAN, LAN, MAN, WAN may mean different things
 - Service, network technology, networks
- Information type
 - Data networks vs. telecommunication networks vs. internal computer networks
- Application type
 - Special purpose networks: Sensing, airline reservation network, banking network, credit card network, telephony
 - General purpose network: Internet

Types of Networks

- Right to use
 - Private: enterprise networks
 - Public: telephony network, Internet
- Ownership of protocols
 - Proprietary: SNA
 - Open: IP
- Technologies
 - Terrestrial vs. satellite
 - Wired vs. wireless
- Protocols
 - IP, AppleTalk, SNA

The Internet (cont'd)

- Global scale, general purpose, heterogeneous-technologies, public, computer network
- Internet Protocol
 - Open standard: Internet Engineering Task Force (IETF) as standard body (<http://www.ietf.org>)
 - Technical basis for other types of networks
 - Intranet: enterprise IP network
- Developed by the research community

History of the Internet

- 70's: started as a research project, 56 kbps, < 100 computers
- 80-83: ARPANET and MILNET split,
- 85-86: NSF builds NSFNET as backbone, links 6 Supercomputer centers, 1.5 Mbps, 10,000 computers
- 87-90: link regional networks, NSI (NASA), ESNNet(DOE), DARTnet, TWBNet (DARPA), 100,000 computers
- 90-92: NSFNET moves to 45 Mbps, 16 mid-level networks
- 94: NSF backbone dismantled, multiple private backbones
- Today: backbones run at 10 Gbps, 10s millions computers in 150 countries

Time Line of the Internet

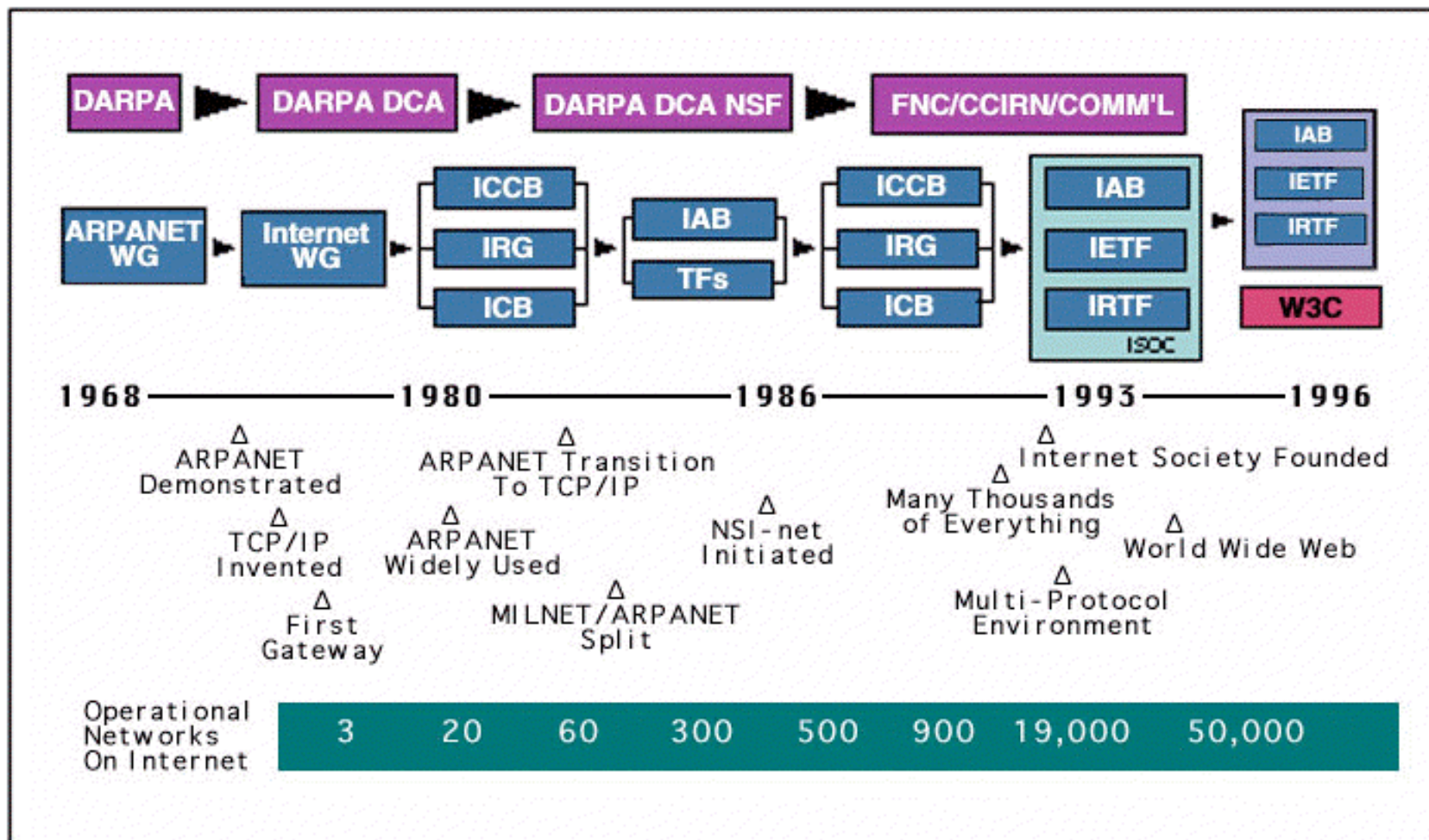

•Source: Internet Society

Growth of the Internet

- **Number of Hosts on the Internet:**

Aug. 1981	213
Oct. 1984	1,024
Dec. 1987	28,174
Oct. 1990	313,000
Oct. 1993	2,056,000
Apr. 1995	5,706,000
Jan. 1997	16,146,000
Jan. 1999	56,218,000
Jan. 2001	109,374,000
Jan 2003	171,638,297
Jan 2005	394,991,609
Jan 2007	433,193,199
Jan 2008	541,677,360

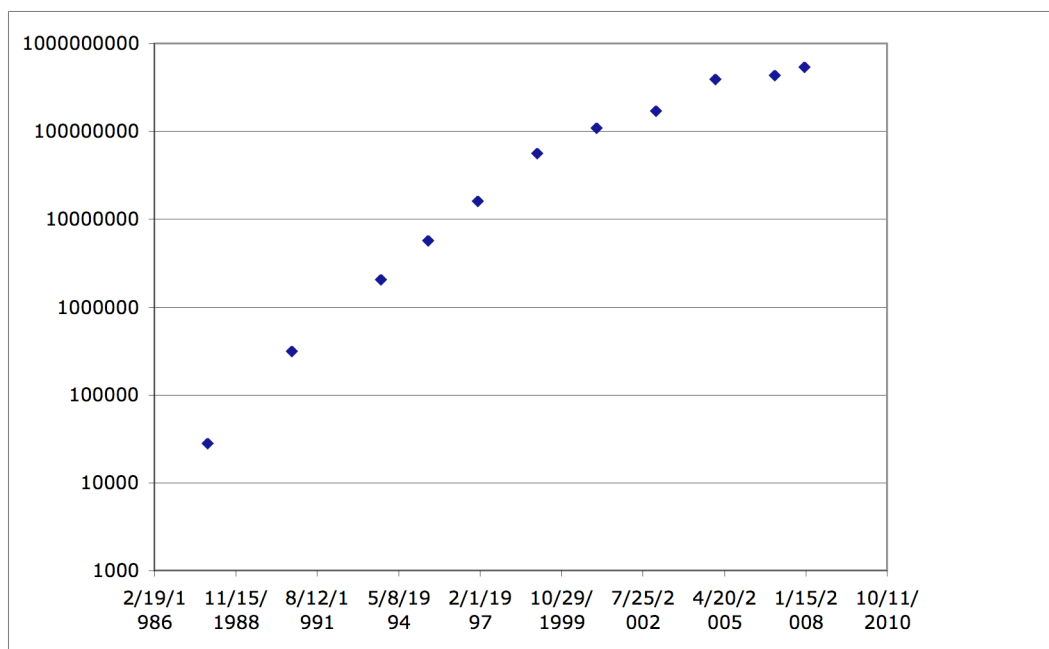

Data available at: <http://www.isc.org/>

Internet Standardization Process

- All standards of the Internet are published as **RFC (Request for Comments)**. But not all RFCs are Internet Standards
 - available: <http://www.ietf.org>
- A typical (but not only) way of standardization is:
 - Internet Drafts
 - RFC
 - Proposed Standard
 - Draft Standard (requires 2 working implementation)
 - Internet Standard (declared by IAB)
- David Clark, MIT, 1992: "We reject: kings, presidents, and voting. We believe in: rough consensus and running code."

Services Provided by the Internet

- Shared access to computing resources
 - Telnet (1970's)
- Shared access to data/files
 - FTP, NFS, AFS (1980's)
- Communication medium over which people interact
 - Email (1980's), on-line chat rooms (1990's)
 - Instant messaging, IP Telephony (2000's)
- A medium for information dissemination
 - USENET (1980's)
 - WWW (1990's)
 - Replacing newspaper, magazine?
 - Audio, video (2000's)
 - Replacing radio, CD, TV...

UUNET'S North American Internet Backbone

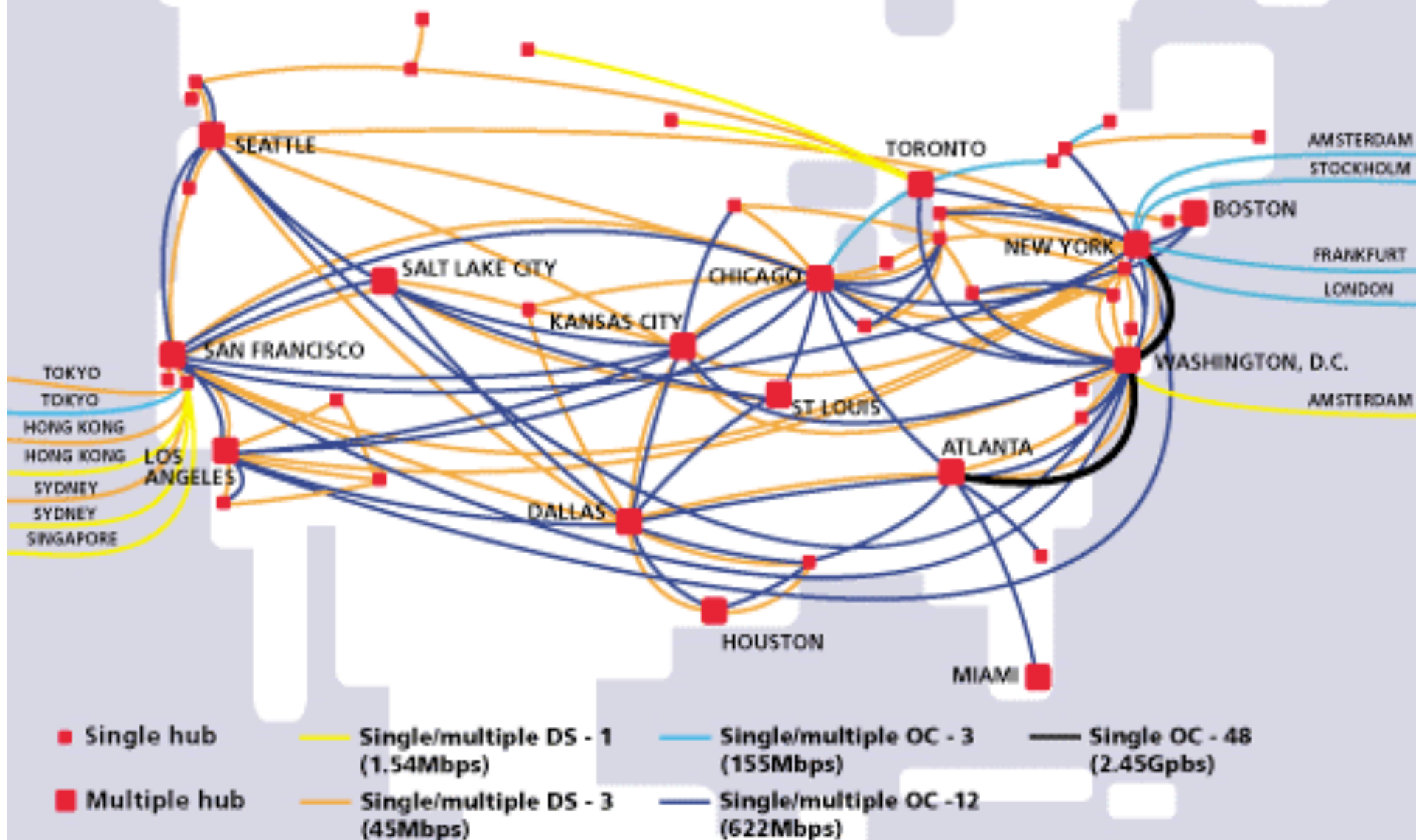

N.B. not all intra-state links are shown

UUNET'S European Internet Backbone

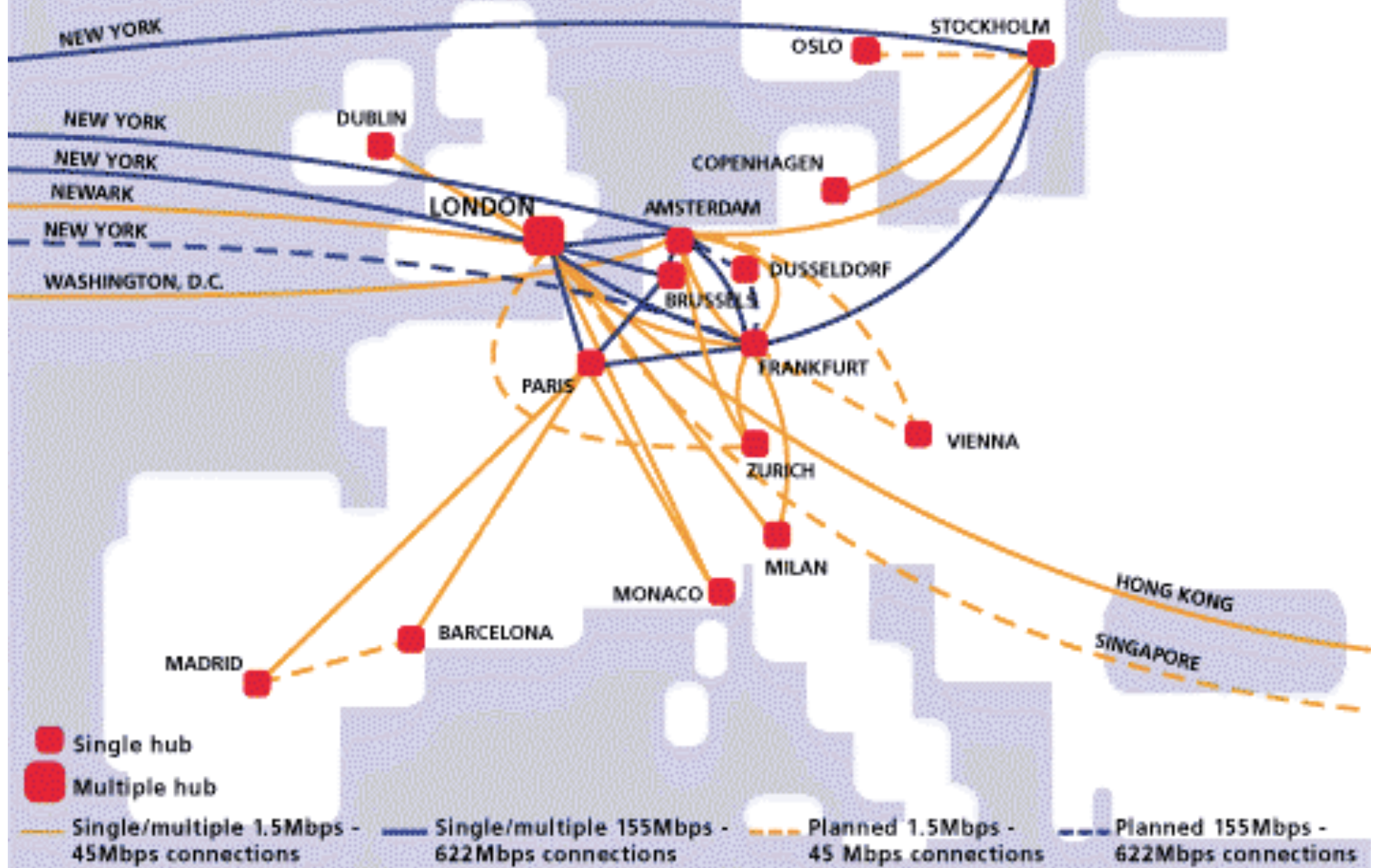

UUNET's Global Internet Backbone

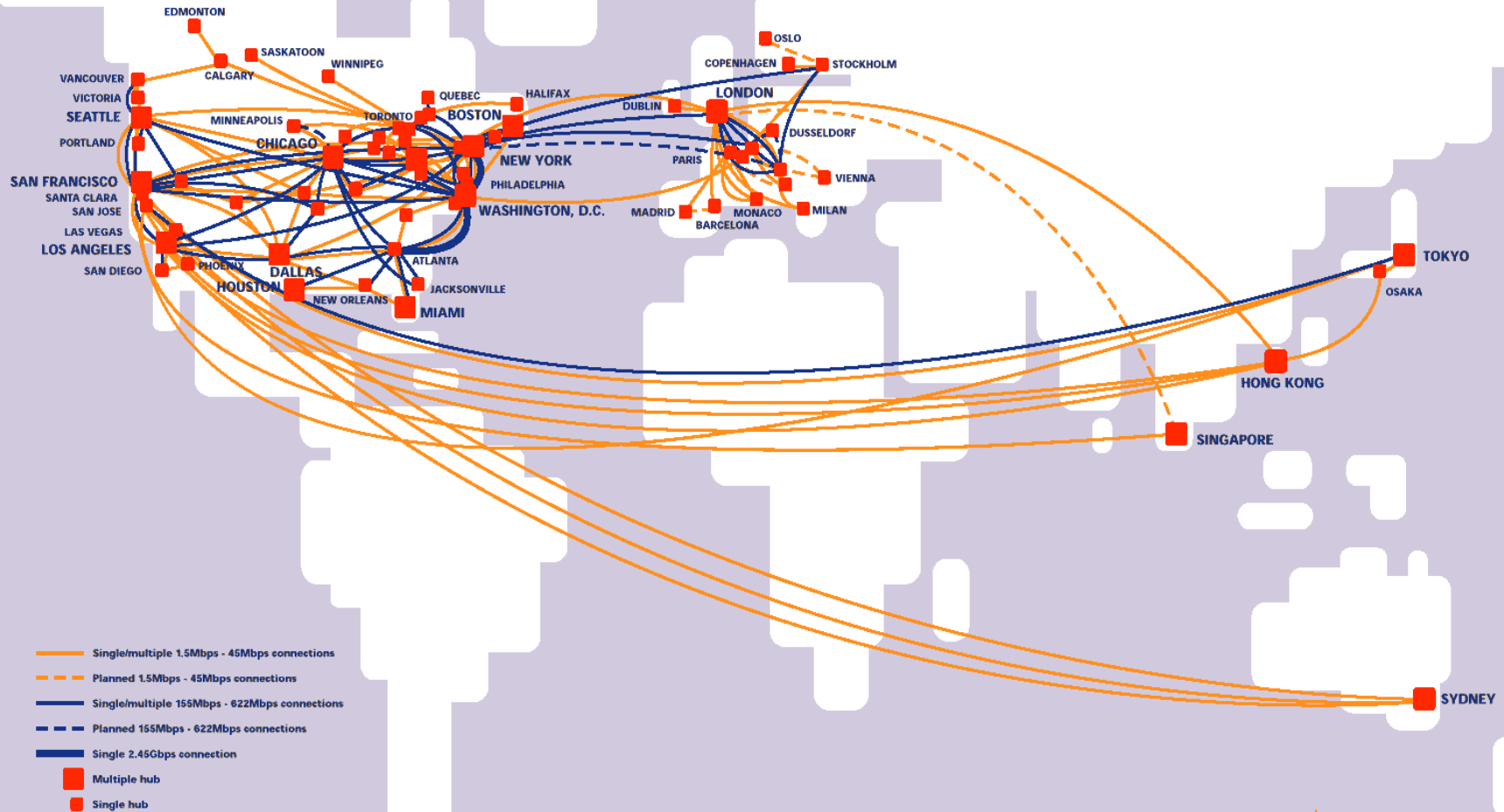

For more information visit www.uu.net

NB: With the exception of North America, Spain & Germany, all major 'in-country' links have been excluded from this map. 'In-state' links within the USA have also been excluded.

This does not constitute a solicitation of any former MCI customer whose dedicated Internet access service was transferred to Cable & Wireless unless the customer was also a WorldCom company Internet services customer as of the MCI WorldCom merger.



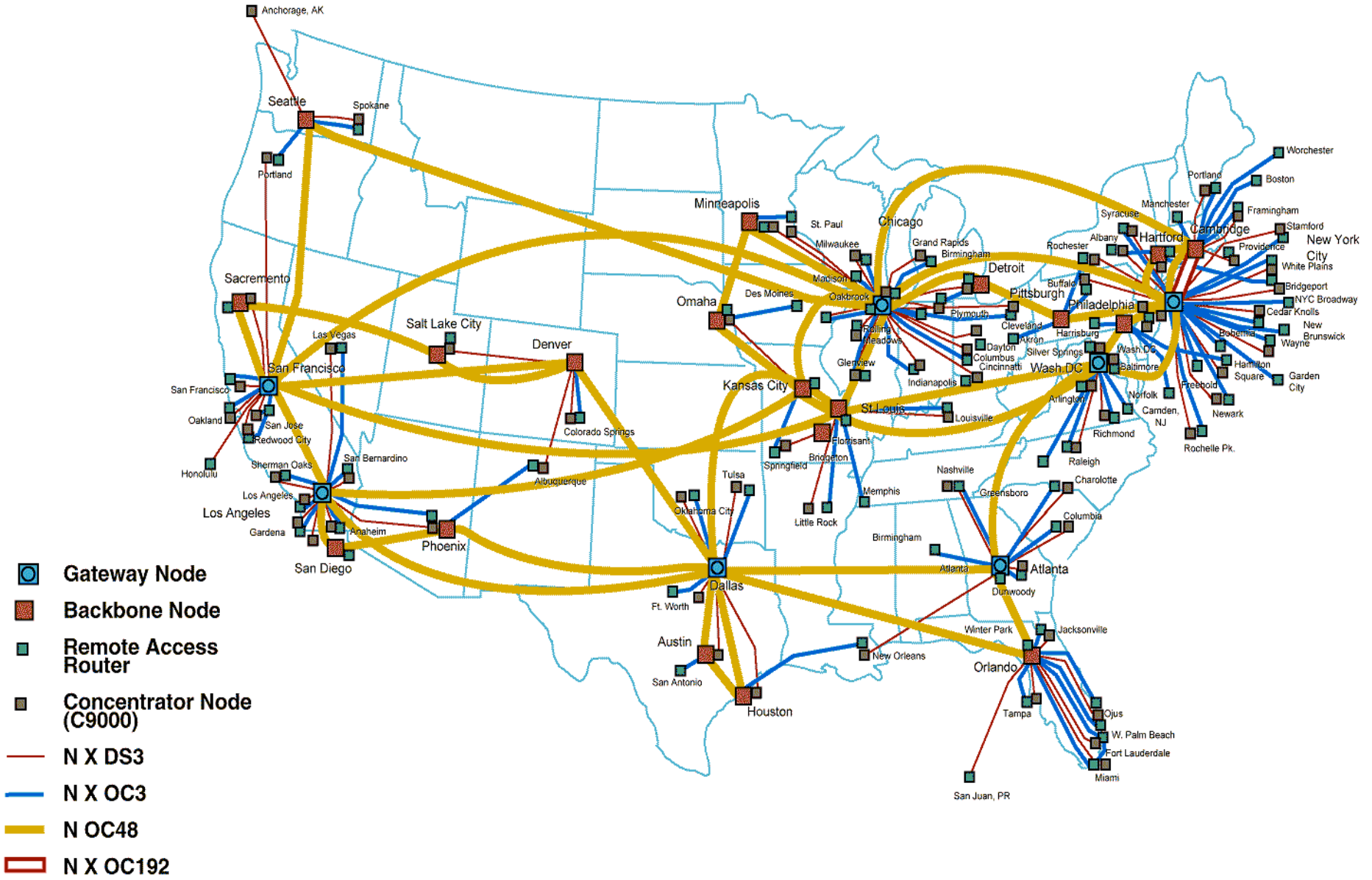

Note: map is not to scale.

Overview

- Administrative
- Course Topics
- Overview and history of the Internet
- A Taxonomy of Communication Networks

A Taxonomy of Communication Networks

- Communication networks can be classified based on the way in which the nodes exchange information:

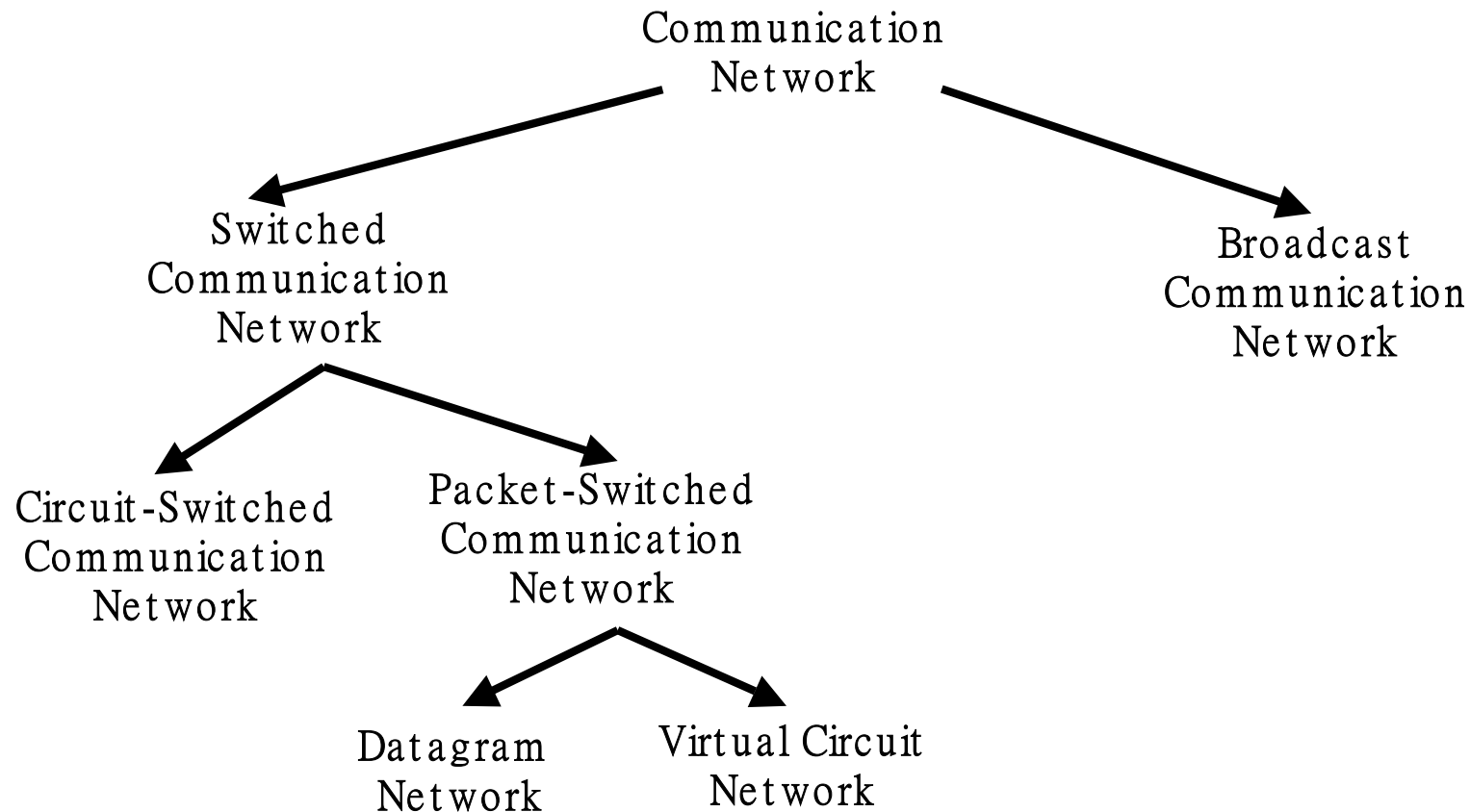

Broadcast vs. Switched Communication Networks

- Broadcast communication networks
 - Information transmitted by any node is received by **every** other node in the network
 - E.g., LANs (Ethernet, Wavelan)
 - Problem: coordinate the access of all nodes to the shared communication medium (Multiple Access Problem)
- Switched communication networks
 - Information is transmitted to a sub-set of designated nodes
 - E.g., WANs (Telephony Network, Internet)
 - Problem: how to forward information to intended node(s)
 - Done by special nodes (e.g., routers, switches) running routing protocols

A Taxonomy of Communication Networks

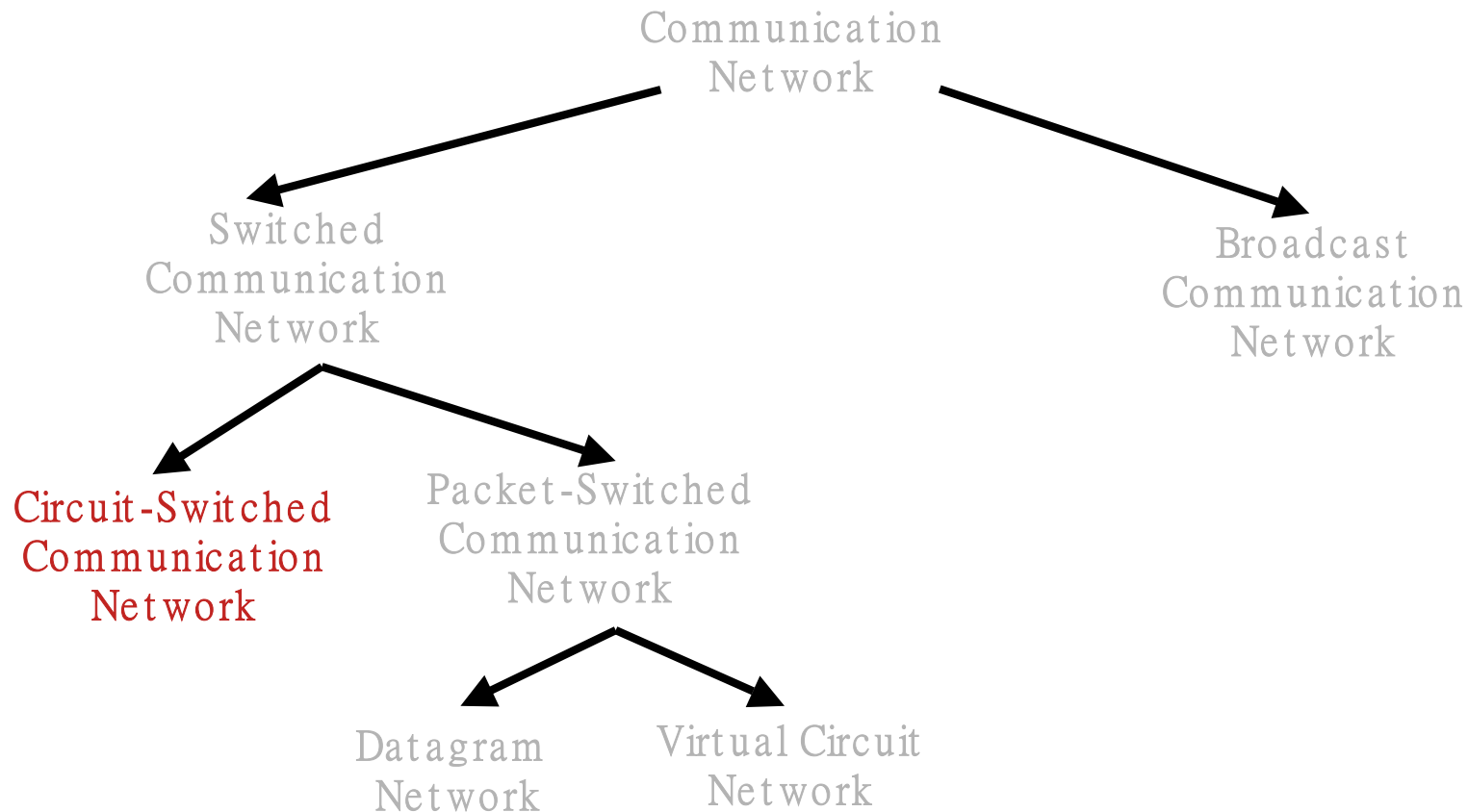

Circuit Switching

- Three phases
 1. circuit establishment
 2. data transfer
 3. circuit termination
- If circuit not available: “Busy signal”
- Examples
 - Telephone networks
 - ISDN (Integrated Services Digital Networks)

Timing in Circuit Switching

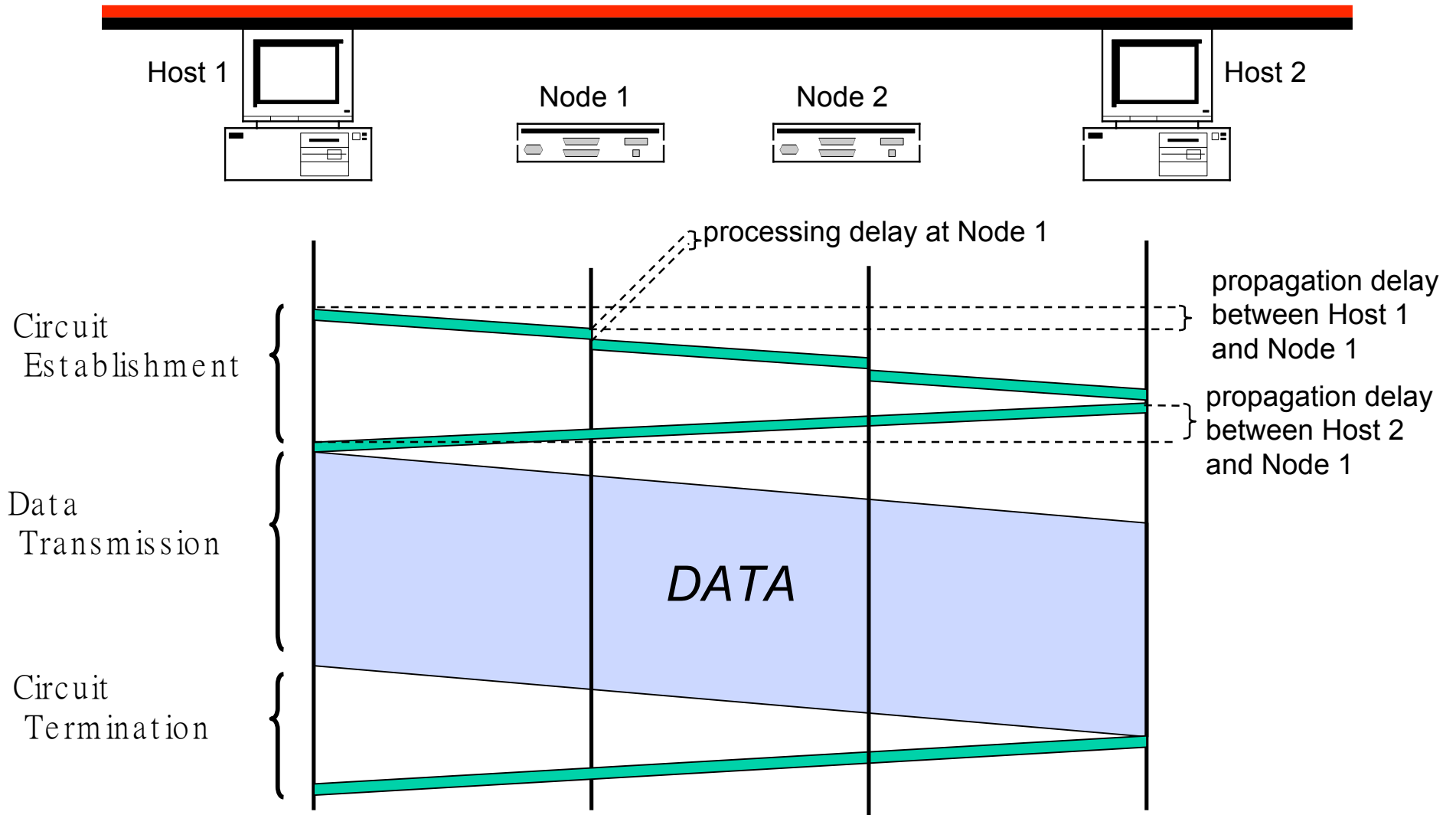

Circuit Switching

- A node (switch) in a circuit switching network

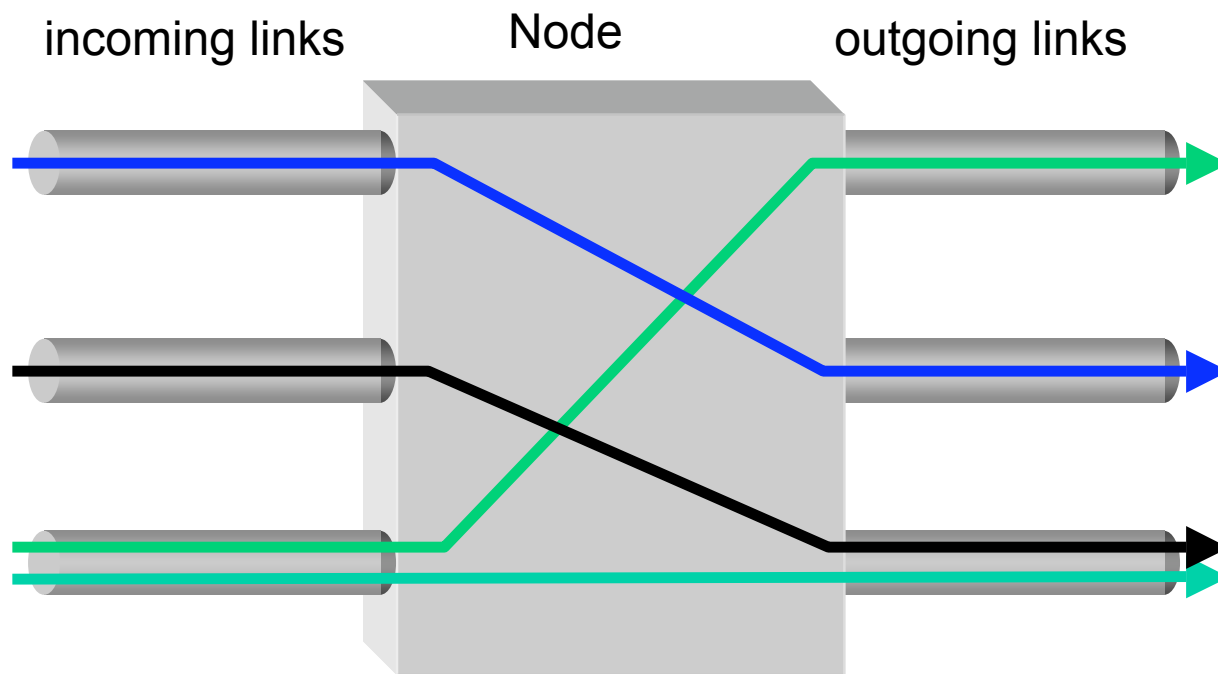

Circuit Switching: Multiplexing/Demultiplexing

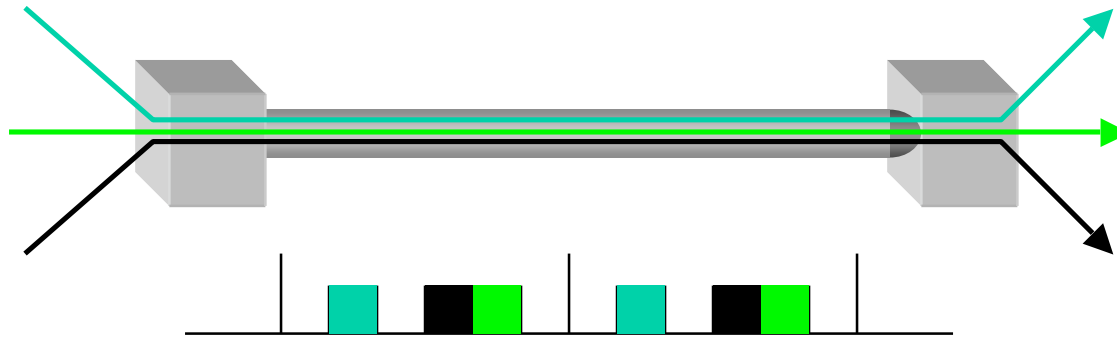

- Time divided in frames and frames divided in slots
- Relative slot position inside a frame **determines** which conversation the data belongs to
- Needs synchronization between sender and receiver
- In case of non-permanent conversations
 - Needs to dynamic bind a slot to a conversation
 - How to do this?

A Taxonomy of Communication Networks

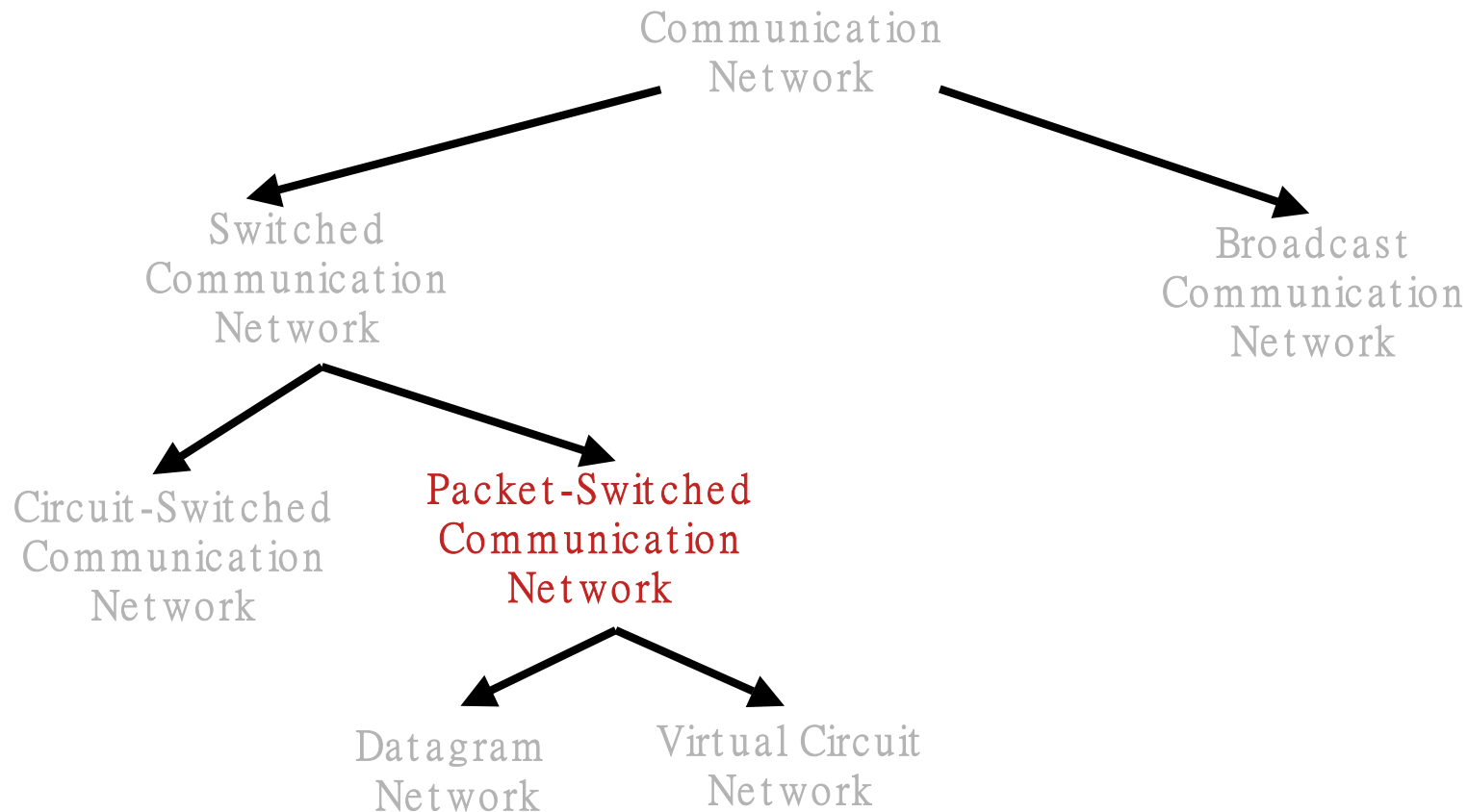

Packet Switching

- Data are sent as formatted bit-sequences, so-called packets
- Packets have the following structure:

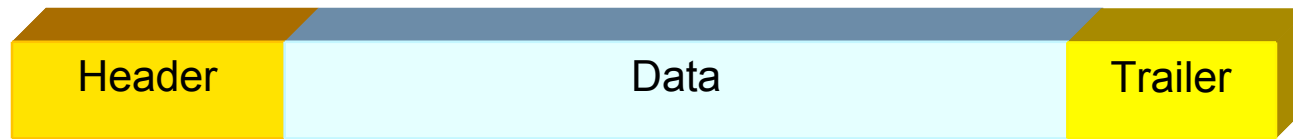

- Header and Trailer carry control information (e.g., destination address, check sum)
- Each packet is passed through the network from node to node along some path (**Routing**)
- At each node the entire packet is received, stored briefly, and then forwarded to the next node (**Store-and-Forward Networks**)
- Typically no capacity is allocated for packets

Packet Switching

- A node in a packet switching network

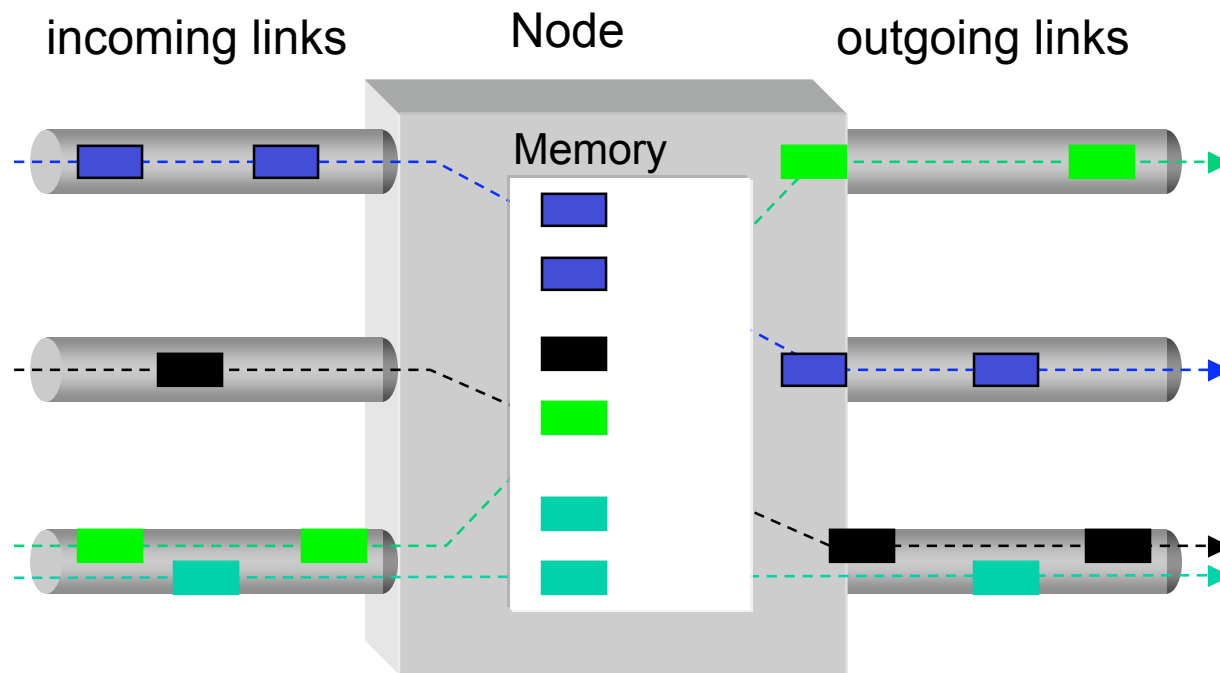

Packet Switching: Multiplexing/Demultiplexing

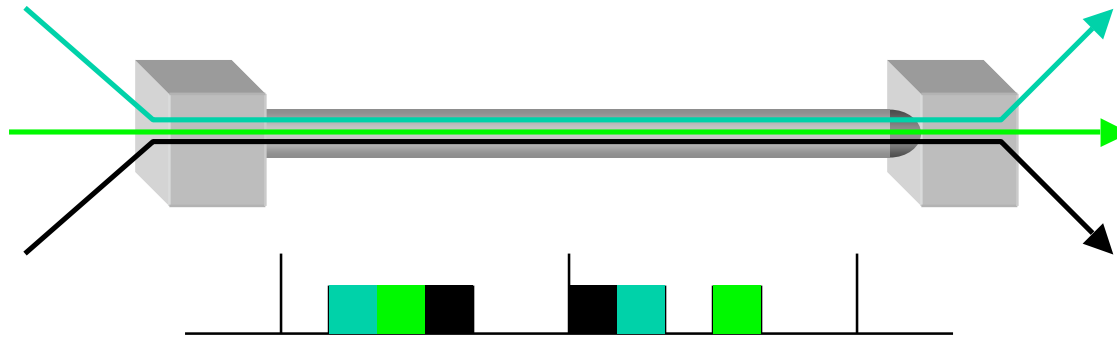

- Data from any conversation can be transmitted at any given time
- How to tell them apart?
 - Use **meta-data (header)** to describe data

A Taxonomy of Communication Networks

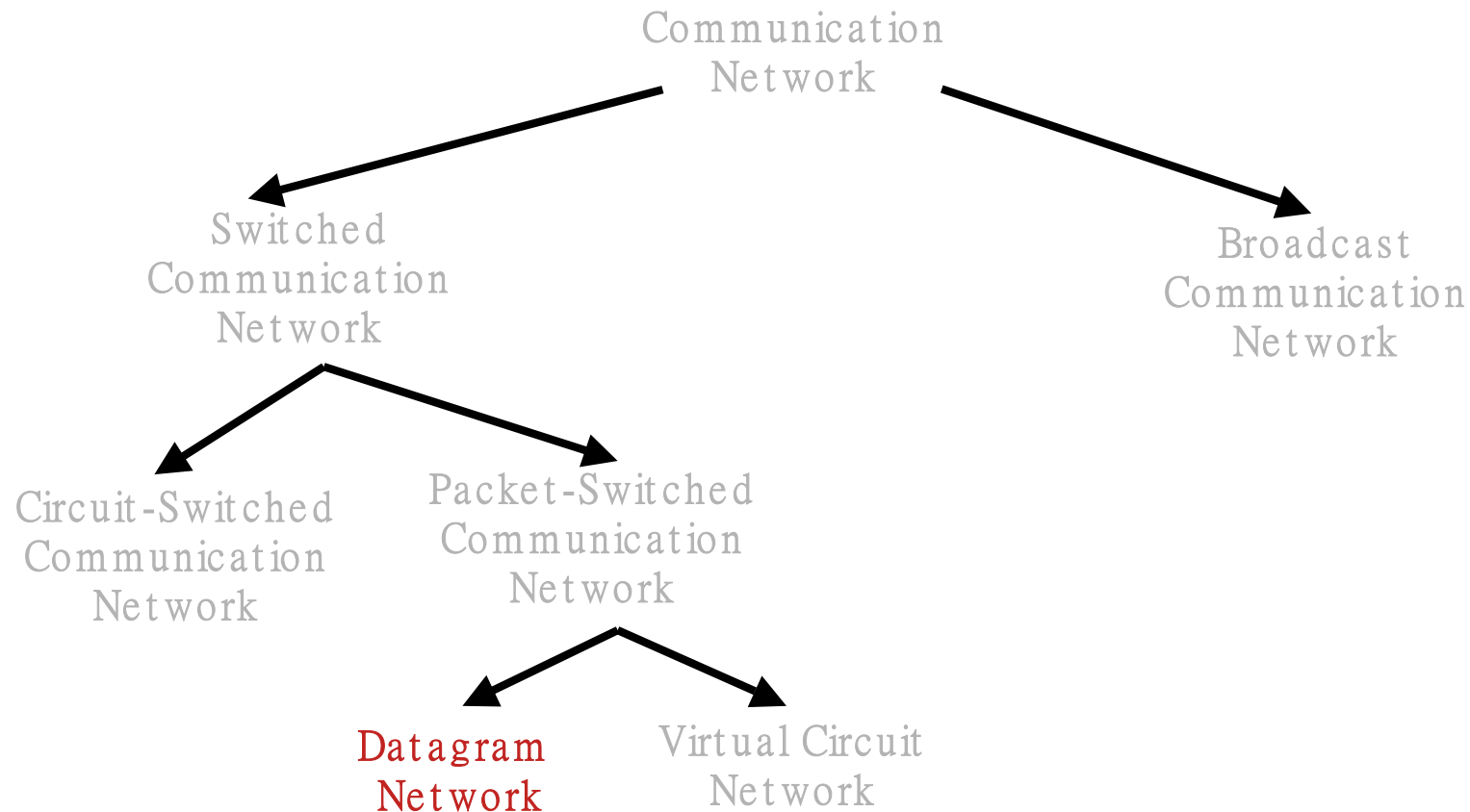

Datagram Packet Switching

- Each packet is independently switched
 - Each packet header contains destination address
- No resources are pre-allocated (reserved) in advance
- Example: IP networks

Timing of Datagram Packet Switching

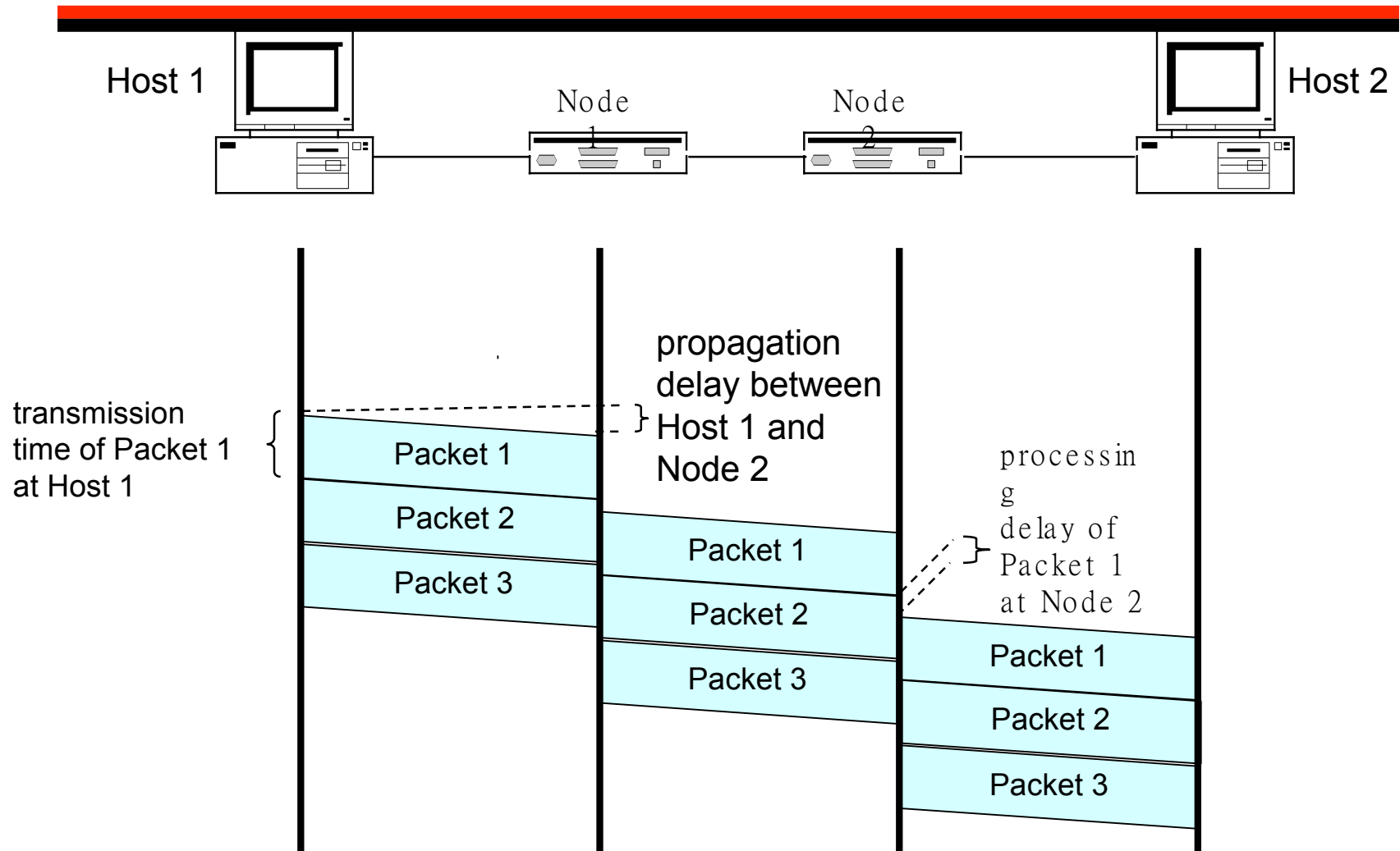

Datagram Packet Switching

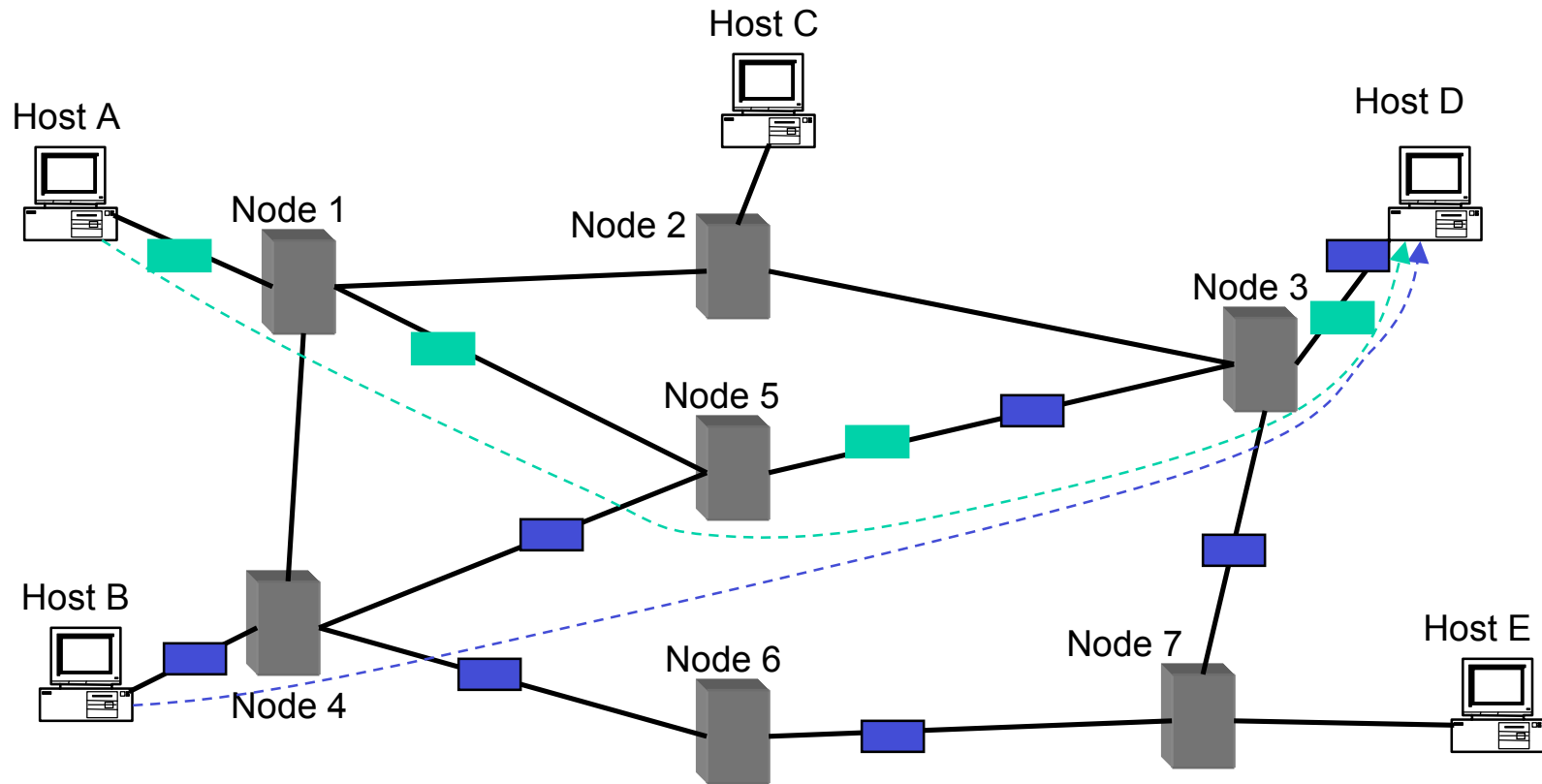

A Taxonomy of Communication Networks

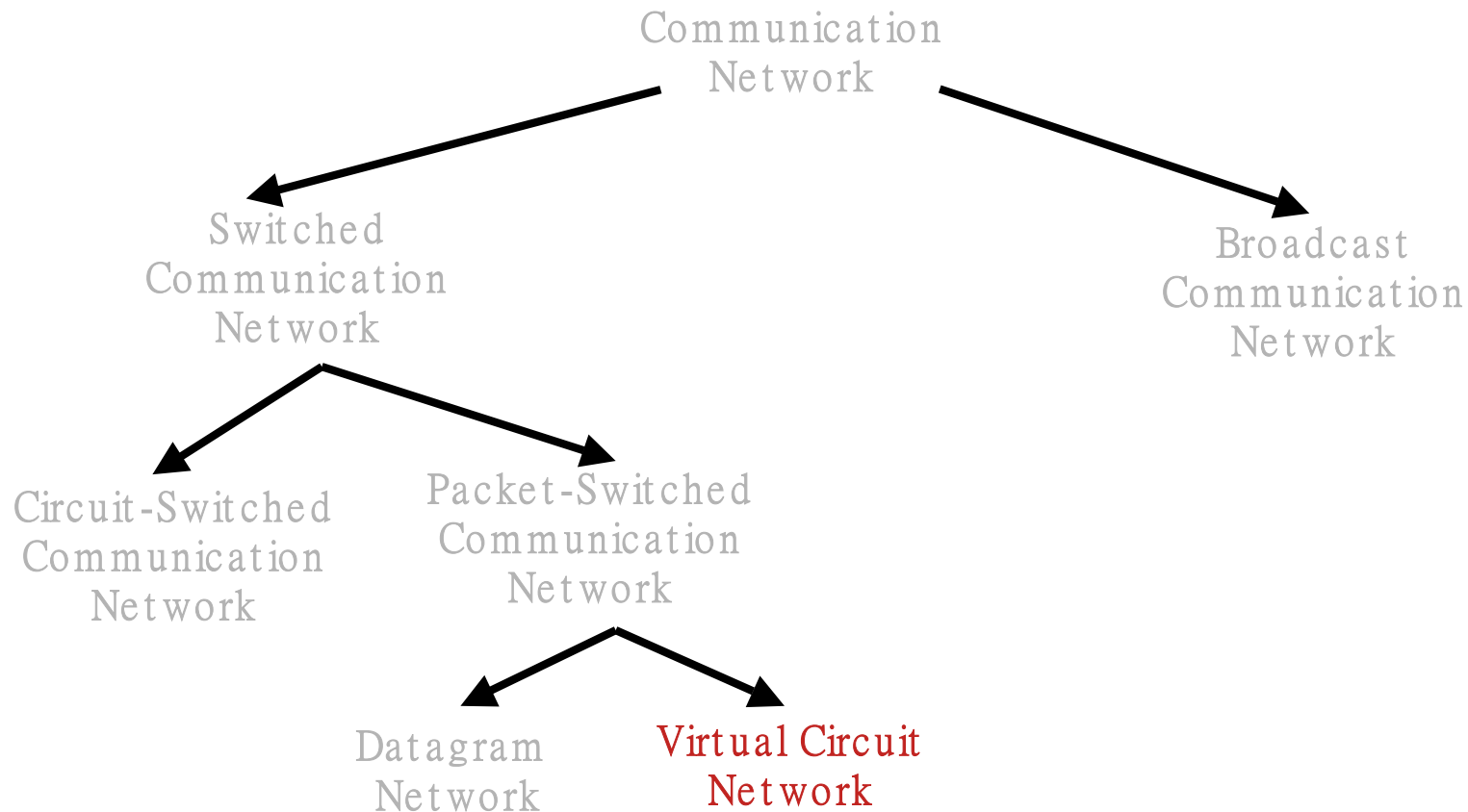

Virtual-Circuit Packet Switching

- Hybrid of circuit switching and packet switching
 - Data is transmitted as packets
 - All packets from one packet stream are sent along a pre-established path (=virtual circuit)
- Guarantees in-sequence delivery of packets
- **However:** Packets from different virtual circuits may be interleaved
- Example: ATM networks

Virtual-Circuit Packet Switching

- Communication with virtual circuits takes place in three phases
 1. VC establishment
 2. data transfer
 3. VC disconnect
- Note: packet headers don't need to contain the full destination address of the packet

Timing of Datagram Packet Switching

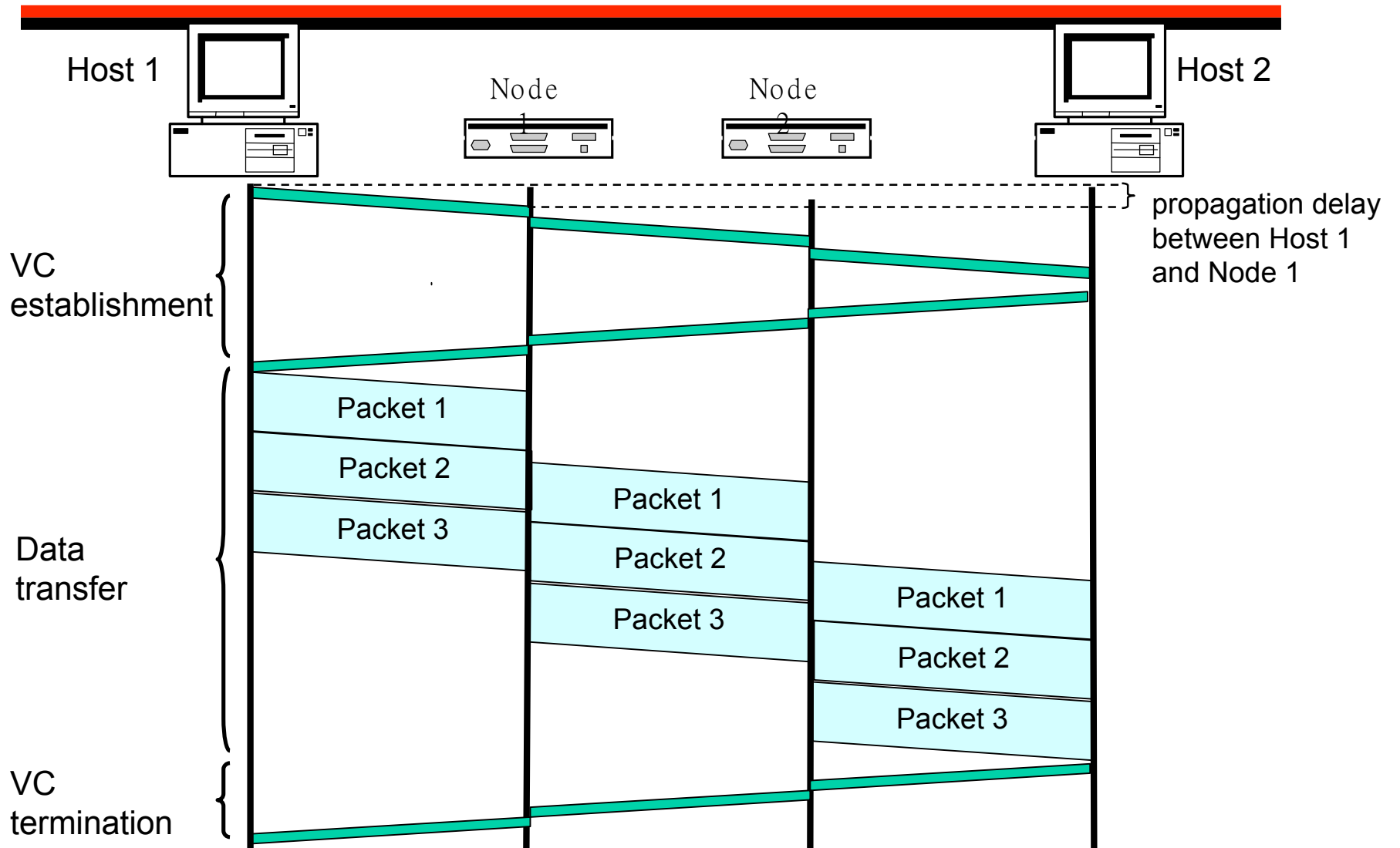

Datagram Packet Switching

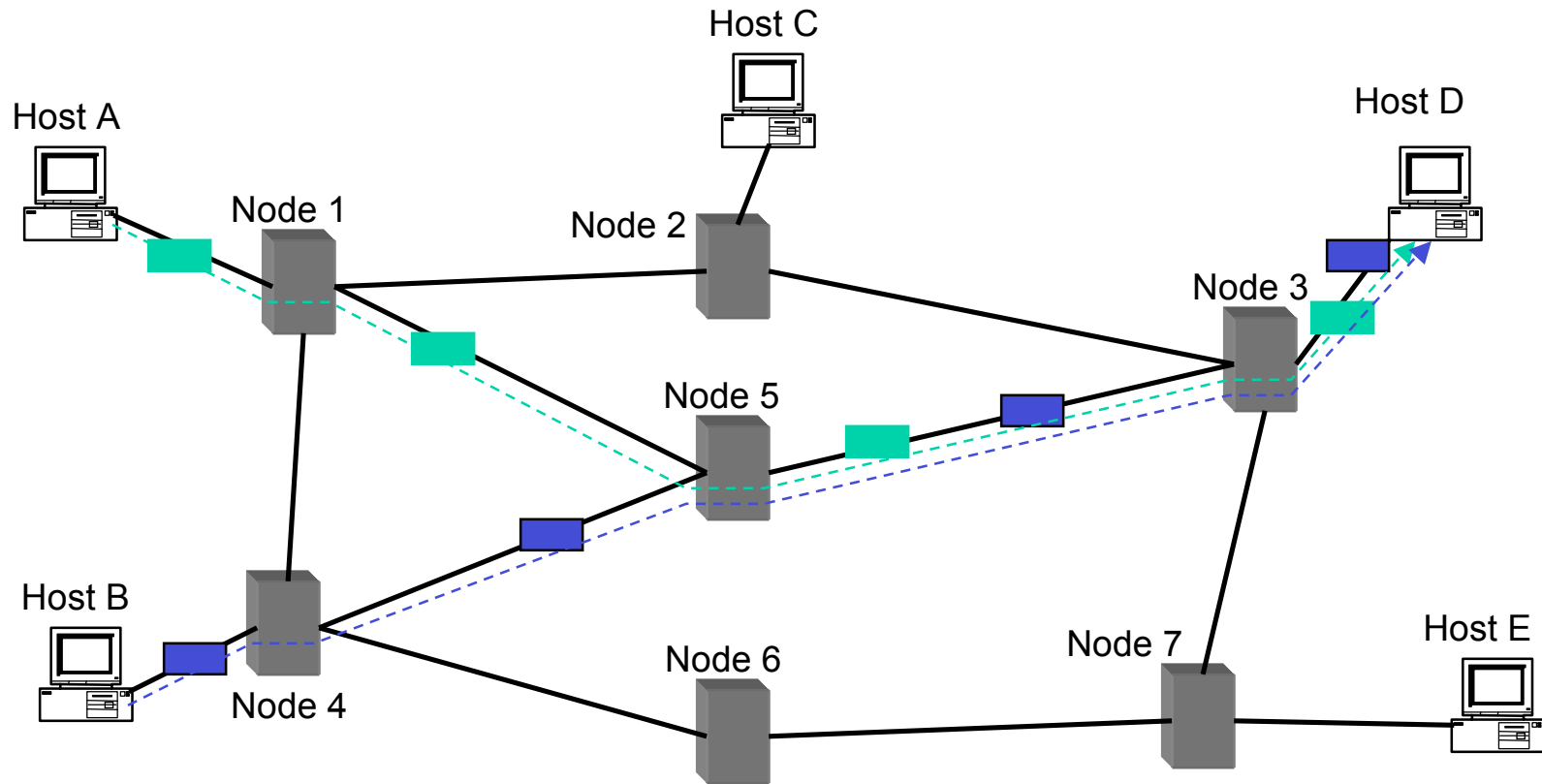

Packet-Switching vs. Circuit-Switching

- Most important advantage of packet-switching over circuit switching: ability to exploit statistical multiplexing:
 - Efficient bandwidth usage; ratio between peak and average rate is 3:1 for audio, and 15:1 for data traffic
- However, packet-switching needs to deal with congestion:
 - More complex routers
 - Harder to provide good network services (e.g., delay and bandwidth guarantees)
- In practice they are combined:
 - IP over SONET, IP over Frame Relay

Network Components (Examples)

Links



Fibers



Coaxial Cable

Interfaces

Ethernet card



Wireless card



Switches/routers

Large router



Telephone switch



Next week

