

Cameras and Image Formation

Ahmed Elgammal
Dept of Computer Science
Rutgers University

Outlines

Cameras, lenses, and image formation

Introduction to Imaging and Multimedia

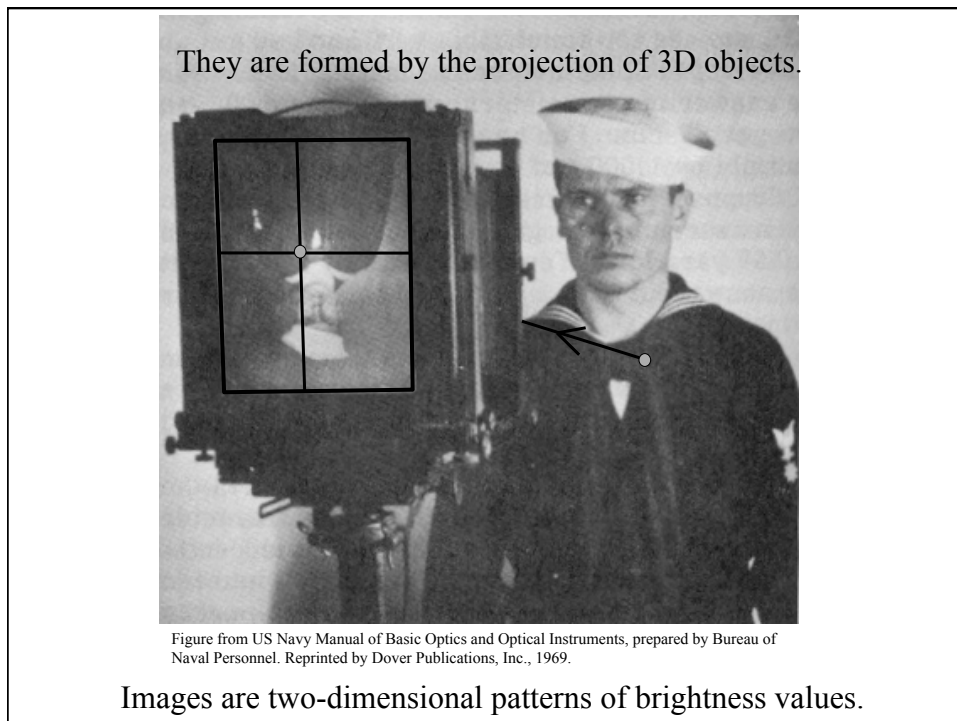
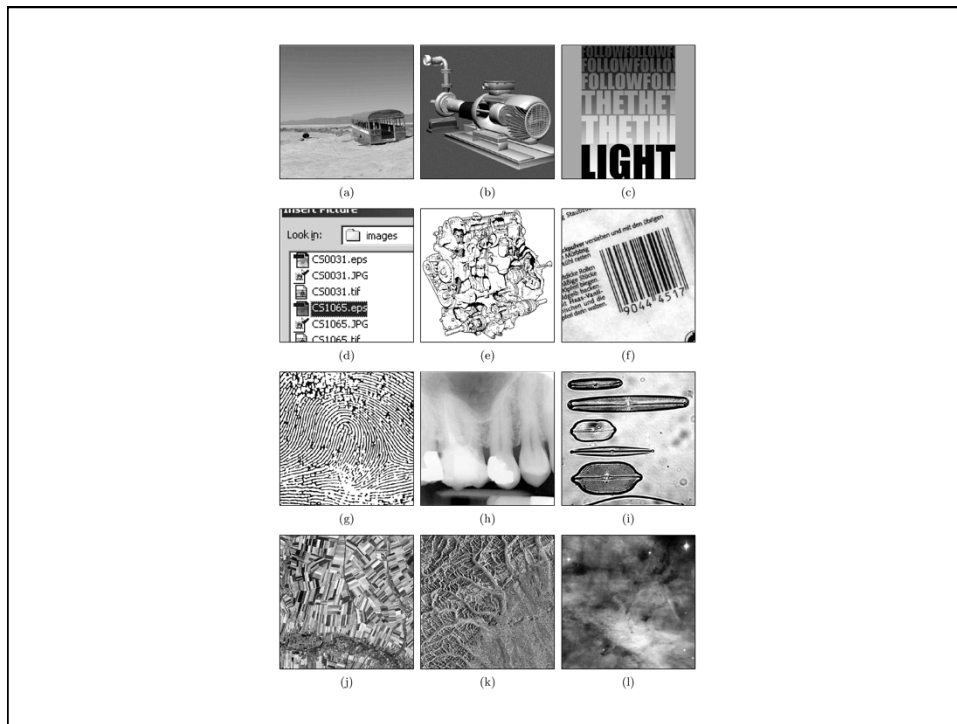

Introduction to Imaging and Multimedia

Reproduced by permission, the American Society of Photogrammetry and Remote Sensing. A.L. Nowicki, "Stereoscopy." Manual of Photogrammetry, Thompson, Radlinski, and Speert (eds.), third edition, 1966.

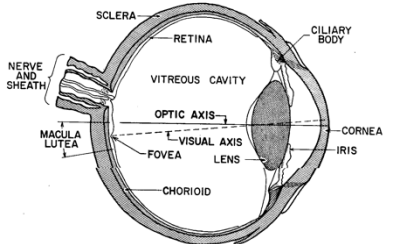

Animal eye: a long time ago.



Photographic camera: Niepce, 1816.

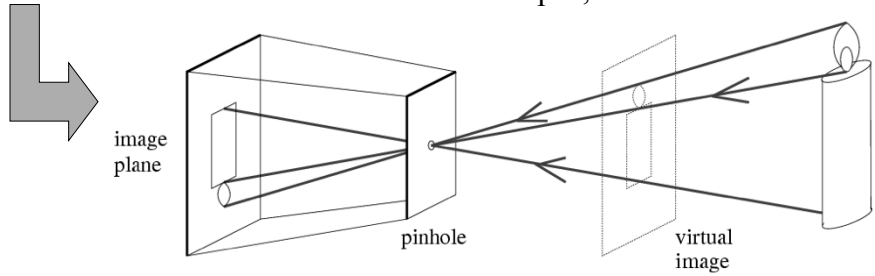

Pinhole perspective projection: Brunelleschi, XVth Century.
Camera obscura: XVIth Century.

Pinhole cameras

-
-
- rays.
- If the pinhole is reduced to a single point (impossible) exactly one ray would pass through each point.

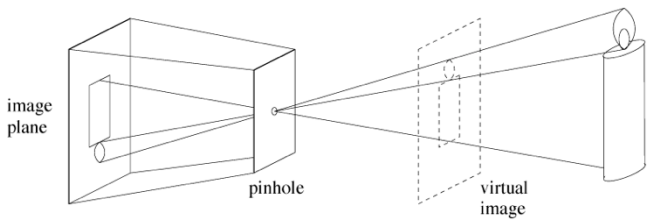

Lensless imaging systems - pinhole optics

- Pinhole optics focuses images
 -
 - depth of field
- Smaller the pinhole
 - better the focus
 - less the light energy from any single point

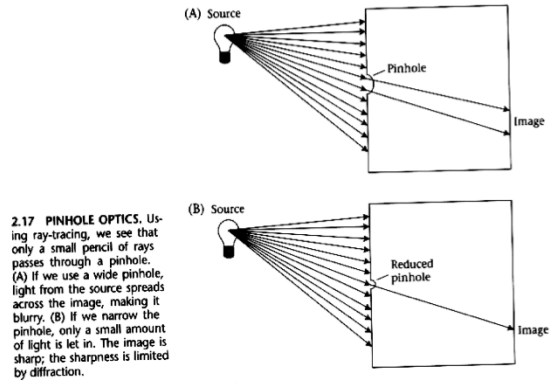

Pinhole too big - many directions are averaged, blurring the image

Pinhole too small- diffraction effects blur the image

Generally, pinhole cameras are *dark*, because a very small set of rays from a particular point hits the screen.

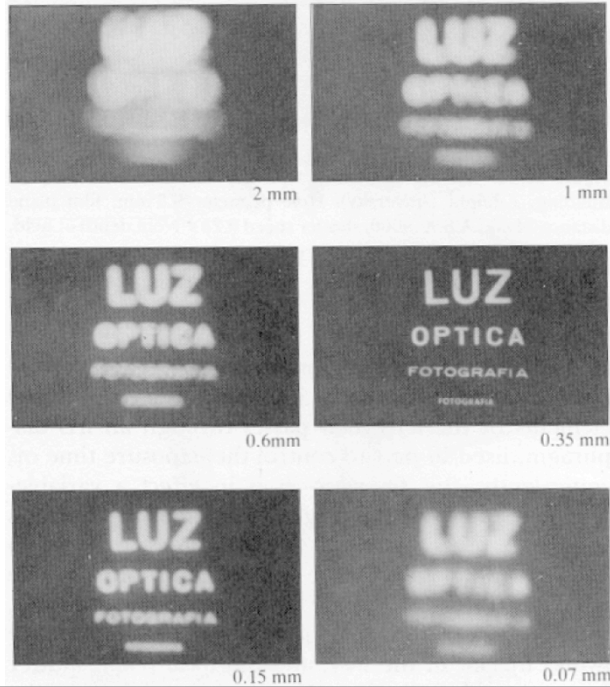

Diffraction

$$\theta = \frac{\lambda}{D}$$

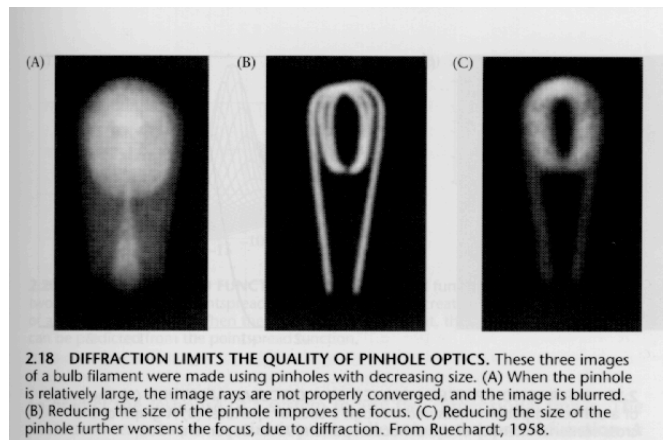

- Two disadvantages to pinhole systems
 -
 -
- Diffraction
 - a straight line
 - it is scattered in many directions
 - process is called diffraction and is a quantum effect
- Human vision
 - at high light levels, pupil (aperture) is small and blurring is due to diffraction
 - at low light levels, pupil is open and blurring is due to lens imperfections

Diffraction and pinhole optics

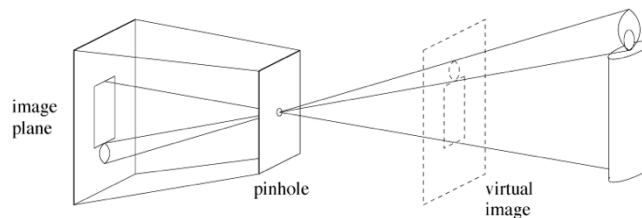

Pinhole Perspective

- Abstract camera model - box with a small hole in it
- Assume a single point pinhole:
 - Pinhole (central) perspective projection {Brunelleschi 15th Century}
 - Extremely simple model for imaging geometry
 - Doesn't strictly apply
 - Mathematically convenient - acceptable approximation.
 - Concepts: image plane, virtual image plane
 - Moving the image plane merely scales the image.



Distant objects are smaller

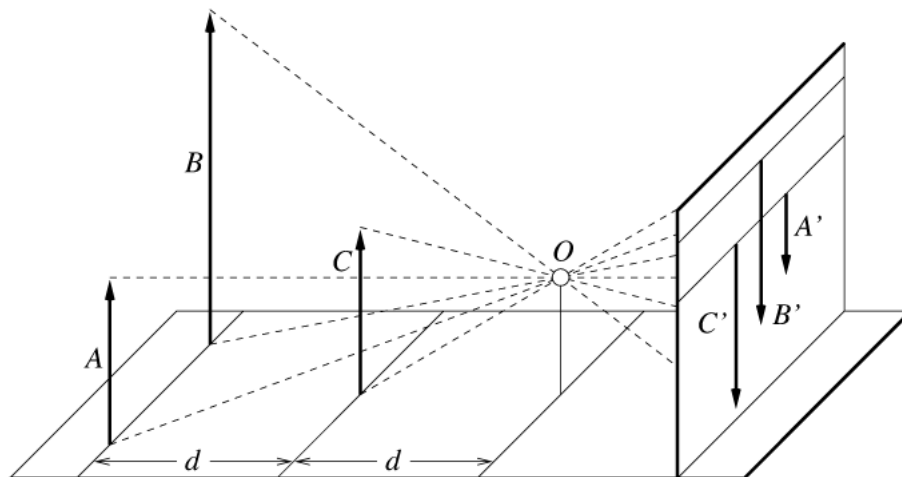

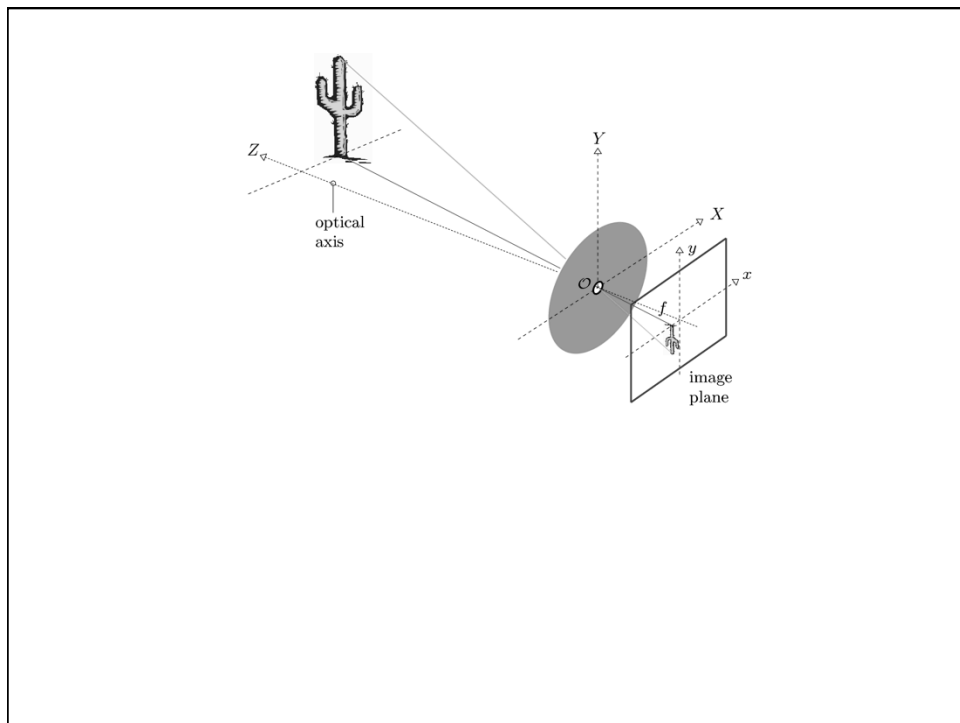
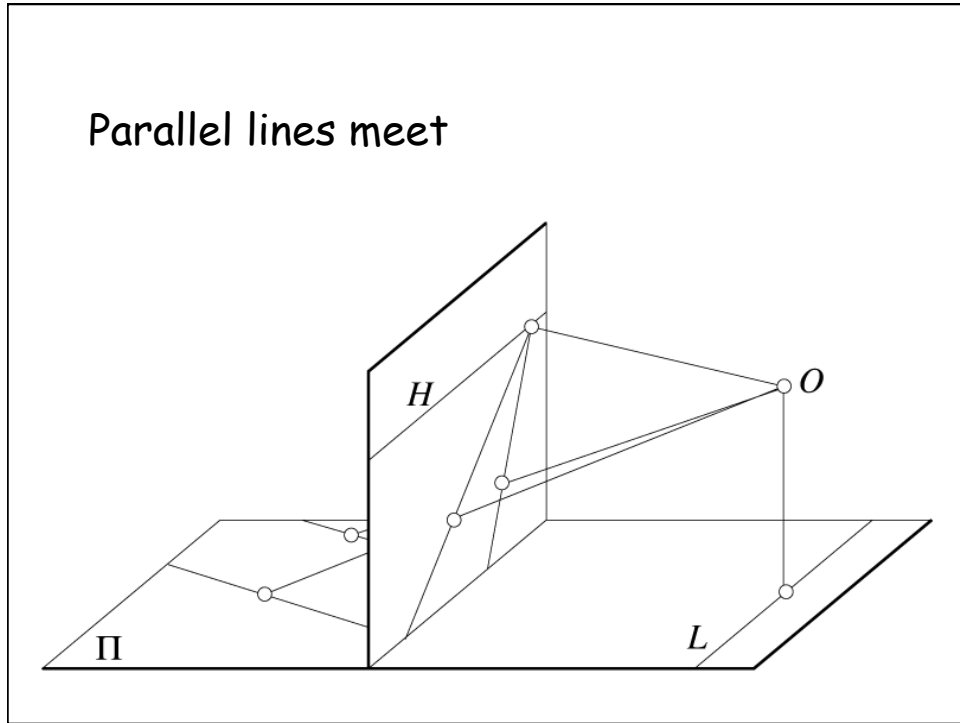

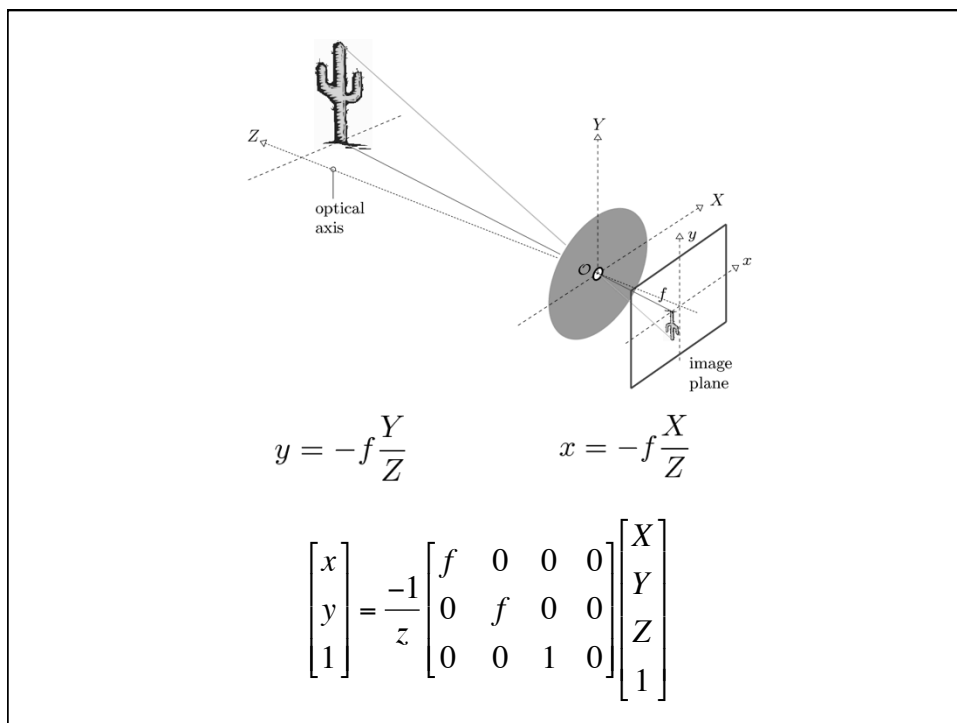
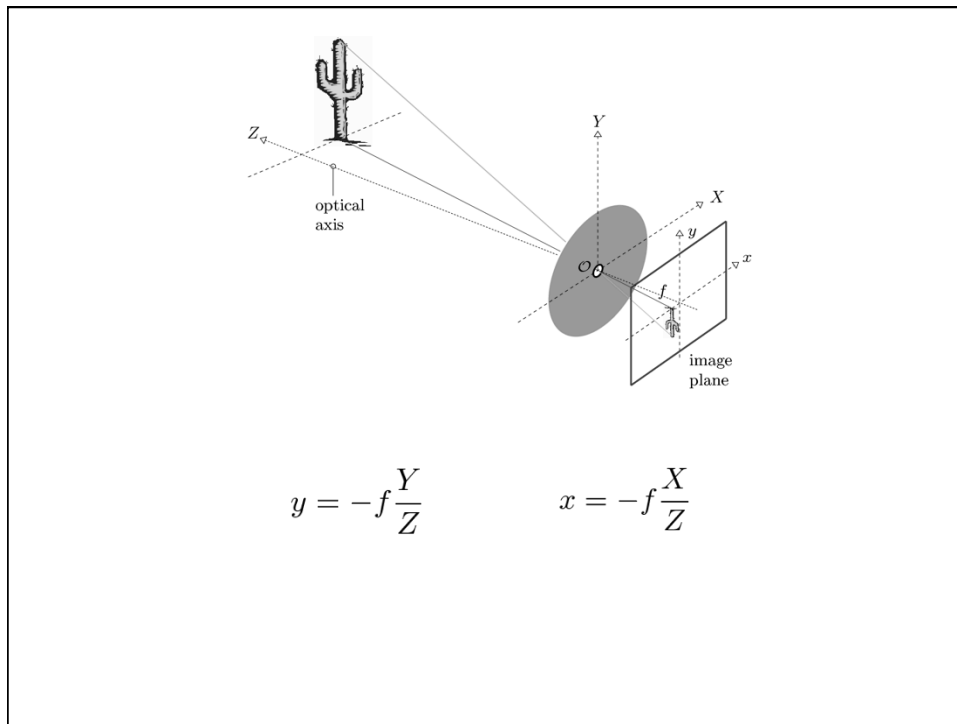

The reason for lenses

- Because of pinhole cameras limitations, we do need lenses
- With a lens, diverging rays from a scene point are converged back to an image point

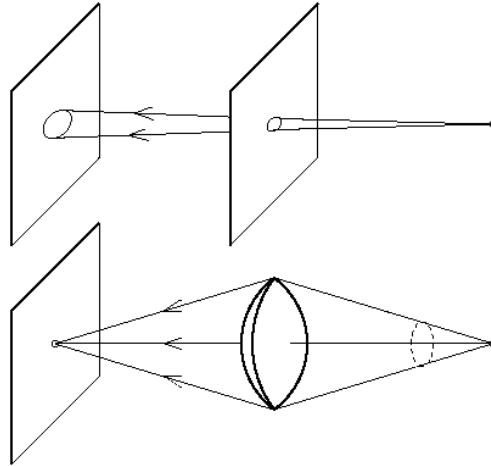

Kepler's retinal theory

Even though light rays from "many" surface points hit the same point on the lens, they approach the lens from different directions.

Therefore, they are refracted in different directions - separated by the lens

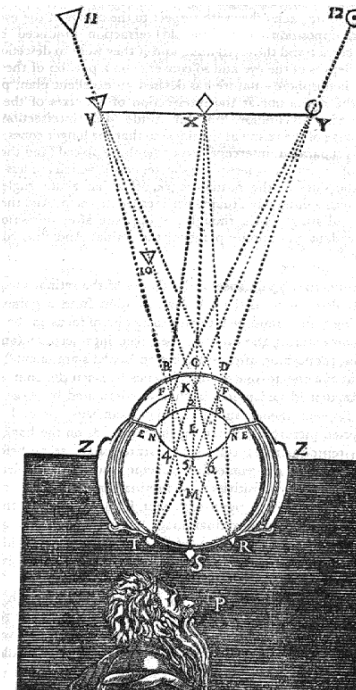

Snell's law

- Willebrord Snellius (Snel) 1621
- Descartes' law !, Earlier known by Ibn Sahl 940-1000!, earlier by Ptolemy!
- If ϕ is the angle of incidence and ϕ' is the angle of refraction then

$$n \sin \phi = n' \sin \phi'$$

Where n and n' are the refractive indices of the two media

- Refractive index is the ratio of speed of light in a vacuum to speed of light in the medium

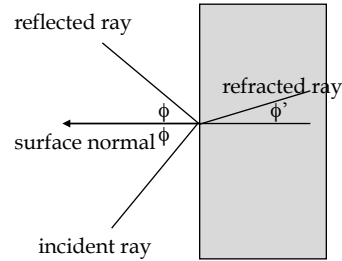

Refractive indices
glass - 1.52
water - 1.333
air - 1.000 - mercifully

Applying Snell's Law twice

- Pass light into and out of a prism (symmetric piece of glass)
 - By combining many infinitesimally small prisms we form a convex lens that will bring all of the refracted rays incident from a given surface point into coincidence at a point behind the lens
 - If the image or film plane is placed that distance behind the lens, then that point will be in focus
 - If the image plane is in front of or behind that ideal location, the image of that point will be out of focus
 - Check out: Fresnel lens

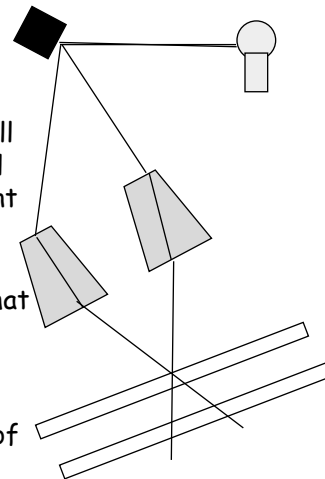

The structure of eyes -compound eyes

- Many (small) animals have compound eyes
 - each photoreceptor has its own lens
 - images seen by these eyes are equally sharp in all directions
 - images seen by these eyes are equally “bright” in all directions when viewing a field of constant brightness
 - examples: flies and other insects
- But these eyes do not “scale” well biologically

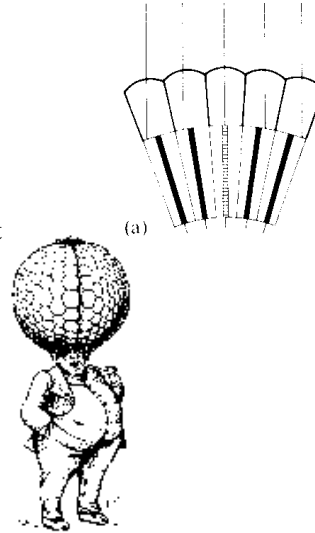

Thin lenses

- The optical behavior is determined by:
 - optical axis going through the lens center O and perpendicular to the lens center plane
 - the left and right focus (F_l and F_r) located a distance f , called the focal length, from the lens center

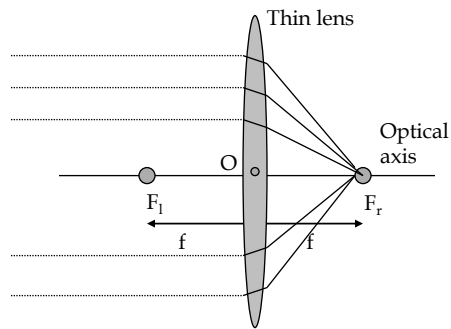

Thin-lens equation

- relates the distance between the point being viewed and the lens to the distance between the lens and the ideal image (where the rays from that point are brought into focus by the lens)
 - Let P be a point being viewed that is not too far from the optical axis.
 - $Z + f$ is the distance of P from the lens along the optical axis
 - The thin lens focuses all the rays from P onto the same point, the image point, p

Thin-lens equation

$$\frac{1}{Z'} + \frac{1}{z'} = \frac{1}{f}$$

- p can be determined by intersecting two known rays, PQ and PR.
 - PQ is parallel to the optical axis, so it must be refracted to pass through F_r .
 - PR passes through the left focus, so emerges parallel to the optical axis.
- Note two pairs of similar triangles
 - $PF_1S \leftrightarrow ROF_1$ and $psF_r \leftrightarrow QOF_r$

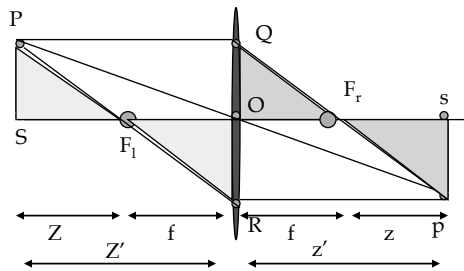

- $PS/OR = Z/f$
- $QO/sp = f/z$
- But $PS = QO$ and $OR = sp$
- So, $Z/f = f/z$, or $Zz = f^2$
- Let $Z' = Z + f$ and $z' = z + f$

$$\frac{1}{Z'} + \frac{1}{z'} = \frac{1}{f}$$

Thin-lens equation

$$\frac{1}{Z'} + \frac{1}{z'} = \frac{1}{f}$$

- Notice that the distance behind the lens, z' , at which a point, P , is brought into focus depends on Z' , the distance of that point from the lens
 - familiar to us from rotating the focus ring of any camera.
- In real lenses, system is designed so that all points within a given range of distances $[Z_1, Z_2]$ are brought into focus at the same distance behind the lens center.
 - This is called the depth of field of the lens.

Thin-lens equation

$$\frac{1}{Z'} + \frac{1}{z'} = \frac{1}{f}$$

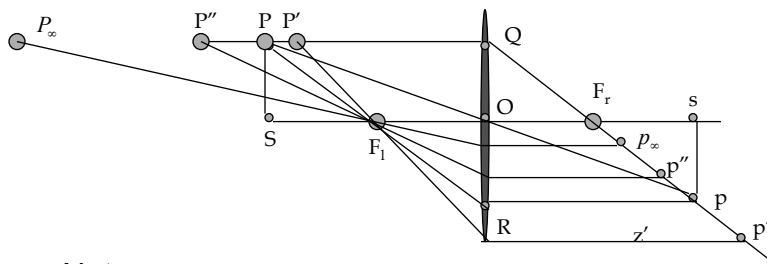

- Note:
 - as Z' gets large, z' approaches f
 - as Z' approaches f , z' approaches infinity

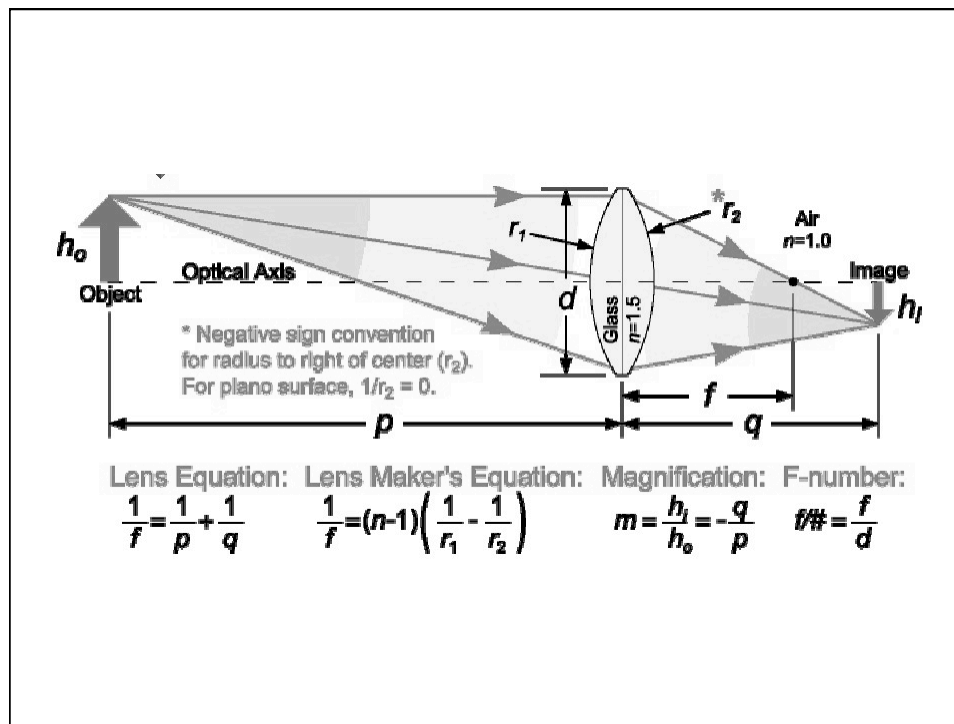

Optical power and accommodation

- Optical power of a lens - how strongly the lens bends the incoming rays
 - short focal length lens bends rays significantly
 - it images a point source at infinity at distance f behind the lens. The smaller f , the more the rays must be bent to bring them into focus sooner.
 - optical power is $1/f$, measured in meters. The unit is called the *dioptr*
 - Human vision: when viewing faraway objects the distance from the lens to the retina is .017m. So the optical power of the eye is 58.8 diopters

Accommodation

- How does the human eye bring nearby points into focus on the retina?
 - by increasing the power of the lens
 - muscles attached to the lens change its shape to change the lens power
 - accommodation: adjusting the focal length of the lens
 - bringing points that are nearby into focus causes faraway points to go out of focus
 - depth-of-field: range of distances in focus
- Physical cameras - mechanically change the distance between the lens and the image plane

Accommodation

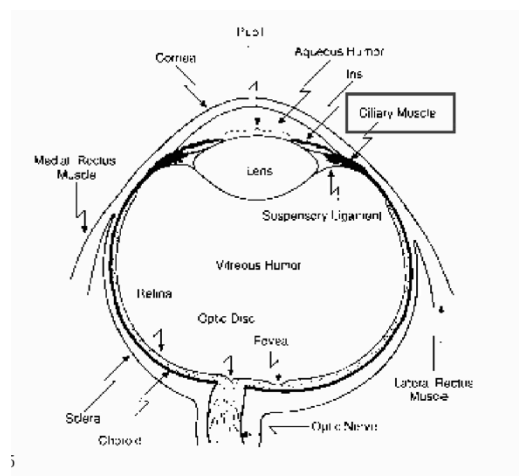

Accommodation

sources at > 1 meter are imaged at same distance
sources closer than 1 m are imaged at different distances

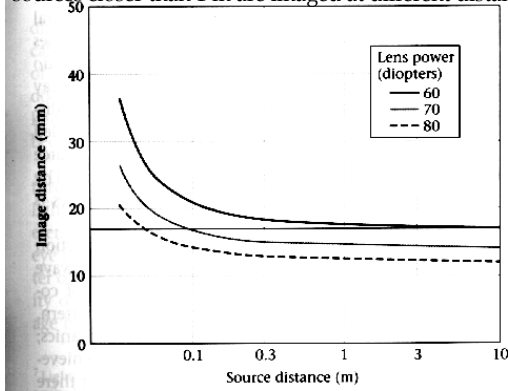

2.16 DEPTH OF FIELD OF THE HUMAN EYE. Image distance is shown as a function of source distance. The solid horizontal line shows the distance of the retina from the lens center. A lens power of 60 diopters brings distant objects into focus, but not nearby objects; to bring nearby objects into focus the power of the lens must increase. The depth of field (the distance over which objects will continue to be in reasonable focus) can be estimated from the slope of the curve.

Real lenses

- Thick lenses

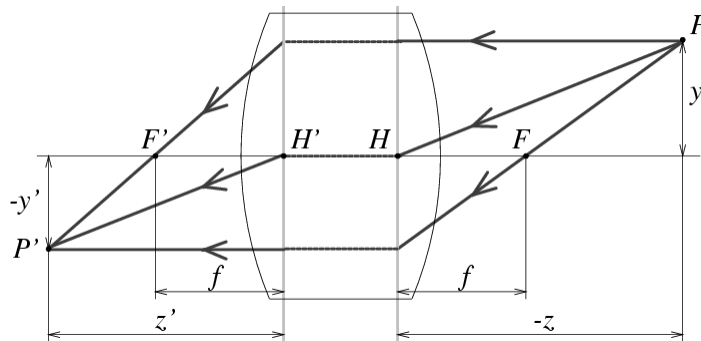

Lens imperfection

- Lens imperfections might cause rays not to intersect at a point
 - deviations in shape from the ideal lens
 - material imperfections that might cause the refractive index to vary within the lens
- Scattering at the lens surface
 - Some light entering the lens system is reflected off each surface it encounters (Fresnel's law gives details)
 - Machines: coat the lens, interior
 - Humans: live with it (various scattering phenomena are visible in the human eye)
- Geometric aberrations.
- Chromatic aberrations.

Radial Distortion

- Barrel: image magnification decreases with distance from the optical axis.
- Pincushion: image magnification increases with the distance from the optical axis.

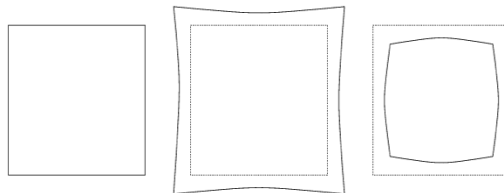

Spherical aberration

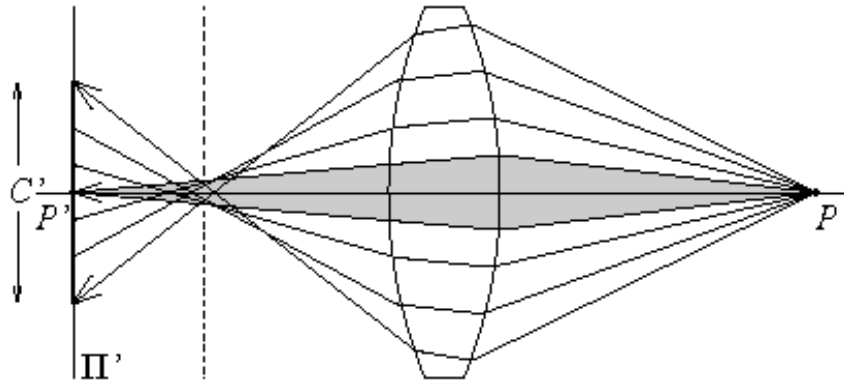

Complications of color

- Spectral composition of light
 - Newton's original prism experiment
 - light decomposed into its spectral components

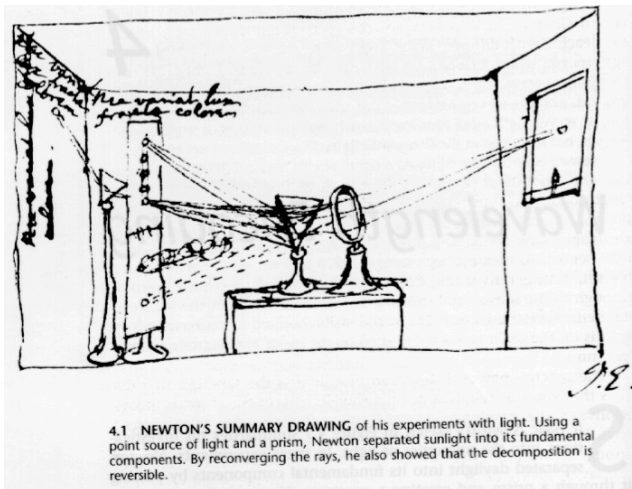

4.1 NEWTON'S SUMMARY DRAWING of his experiments with light. Using a point source of light and a prism, Newton separated sunlight into its fundamental components. By reconverging the rays, he also showed that the decomposition is reversible.

Complications of color

- Why does the prism separate the light into its spectral components?
 - prism bends different wavelengths of light by different amounts
 - refractive index is a function of wavelength
 - shorter wavelengths are refracted more strongly than longer wavelengths

Wavelength	Color (*)
700	Red
610	Orange
580	Yellow
540	Green
480	Blue
400	Violet

* - viewed in isolation

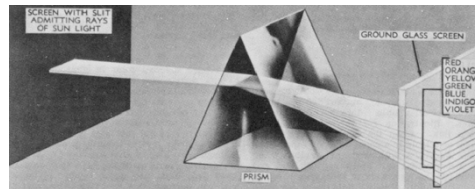
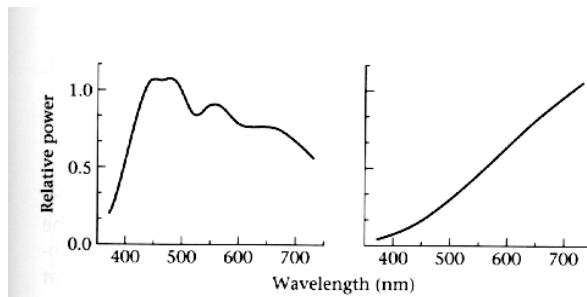

Figure from US Navy Manual of Basic Optics and Optical Instruments, prepared by Bureau of Naval Personnel. Reprinted by Dover Publications, Inc., 1969.

Complications of color



4.4 THE SPECTRAL POWER DISTRIBUTION of two important light sources are shown: (left) blue skylight and (right) a tungsten bulb.

Chromatic aberration

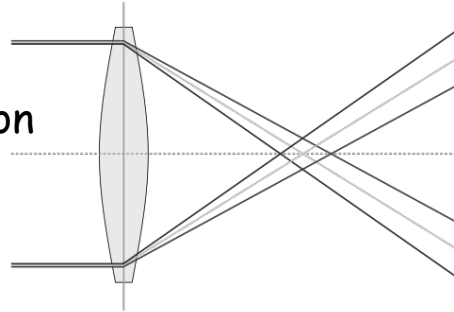

- Chromatic aberration
 - The prism effect of focusing different wavelengths of light from the same point source at different distances behind the lens
 - when incident light is a mixture of wavelengths, we can observe a chromatic fringe at edges
 - accommodation can bring any wavelength into good focus, but not all simultaneously
 - human visual system has other mechanisms for reducing chromatic aberration (adapt to it)
 - color cameras have similar problems



Lens systems

- Aberrations can be minimized by aligning several simple lenses (compound lenses)

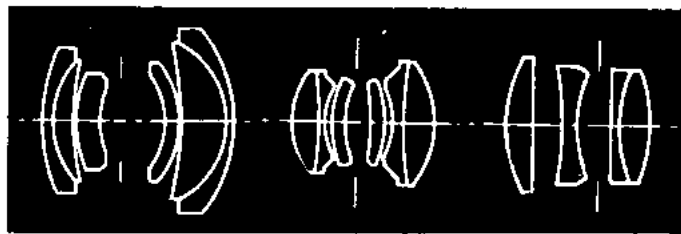

Vignetting

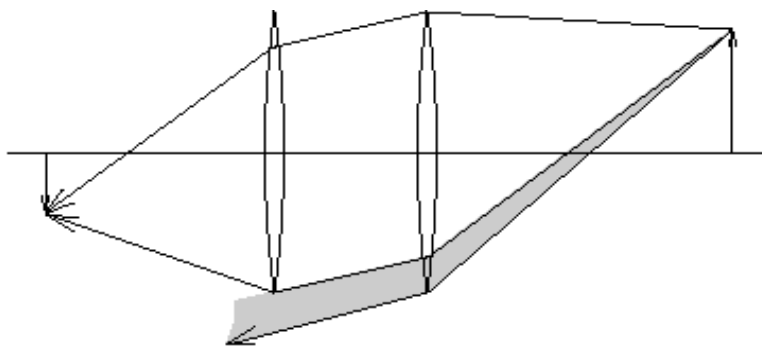

- Vignetting effect in a two-lens system. The shaded part of the beam never reaches the second lens.
- Result: brightness drops at image periphery.

Sensing

Milestones:

First Photograph: Niepce 1816

Daguerreotypes (1839)

Photographic Film (Eastman, 1889)

Cinema (Lumière Brothers, 1895)

Color Photography (Lumière Brothers, 1908)

Television (Baird, Farnsworth, Zworykin, 1920s)

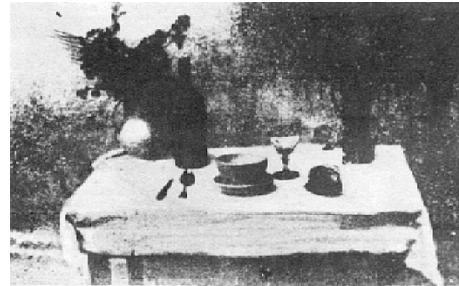

Collection Harlingue-Viollet .

Photographs (Niepce, "La Table Servie," 1822)



"Boulevard du Temple", taken by Daguerre in 1838 in Paris
First person in a photograph. 10 mins exposure

CCD & CMOS

- CCD Cameras (Charge Couple Device) (1970)
 - Accumulate signal charge in each pixel proportional to the local illumination intensity
 - CCD transfers each pixel's charge packet sequentially to convert its charge to a voltage
- CMOS Cameras (Complementary Metal Oxide Silicon)
 - Accumulate signal charge in each pixel proportional to the local illumination intensity
 - The charge-to-voltage conversion takes place in each pixel

CCD cameras

- Charge-coupled device CCD
- Image is read one row at a time
- This process is repeated several times per second (frame rate)

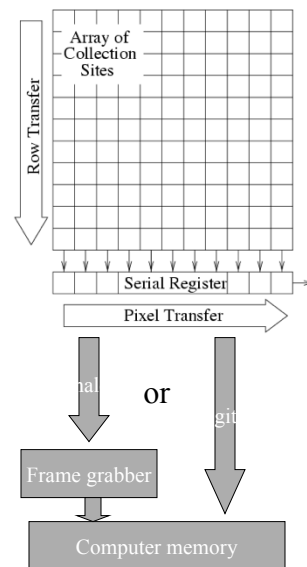
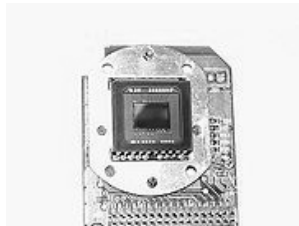

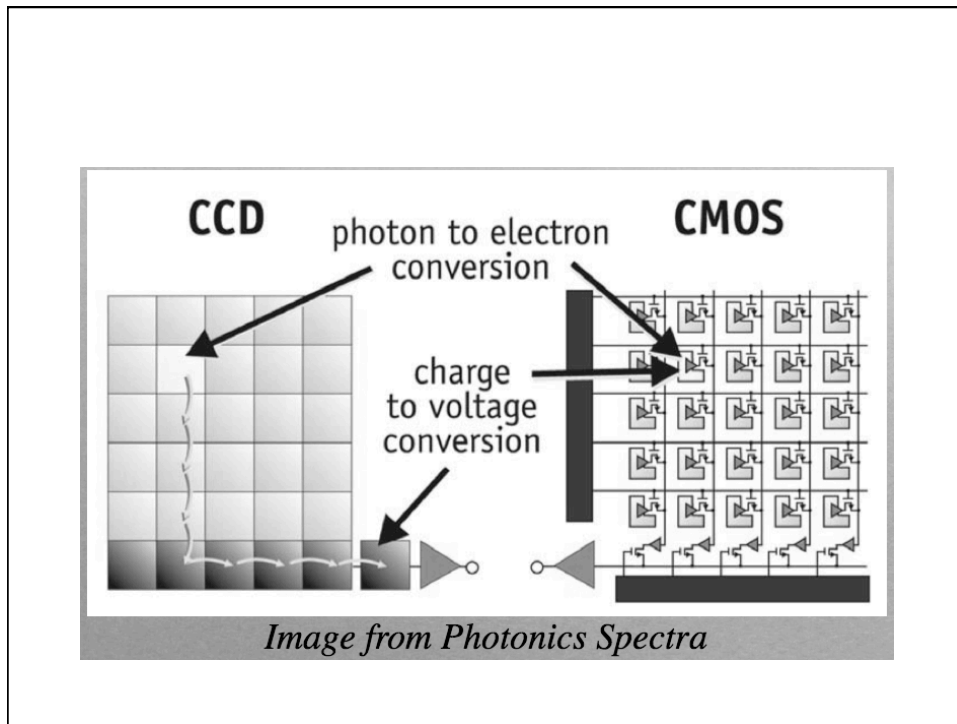

<i>CMOS</i>	<i>CCD</i>
<ul style="list-style-type: none">◦ <i>Easier to manufacture</i>◦ <i>Camera-on-a-chip</i>◦ <i>Lower power consumption</i>◦ <i>Smaller sensor</i>◦ <i>Higher speeds</i>◦ <i>Selective ROI windowing</i>◦ <i>Natural anti-blooming</i>	<ul style="list-style-type: none">◦ <i>Higher fill factor</i>◦ <i>Smaller noise</i>◦ <i>Smaller dark current</i>◦ <i>Better pixel uniformity</i>◦ <i>Better dynamic range</i>◦ <i>Non-rolling electronic shutter</i>

Check out: [CCD vs. CMOS: Facts and Fiction](#) by Dave Litwiler, in Photonics Spectra, January 2001

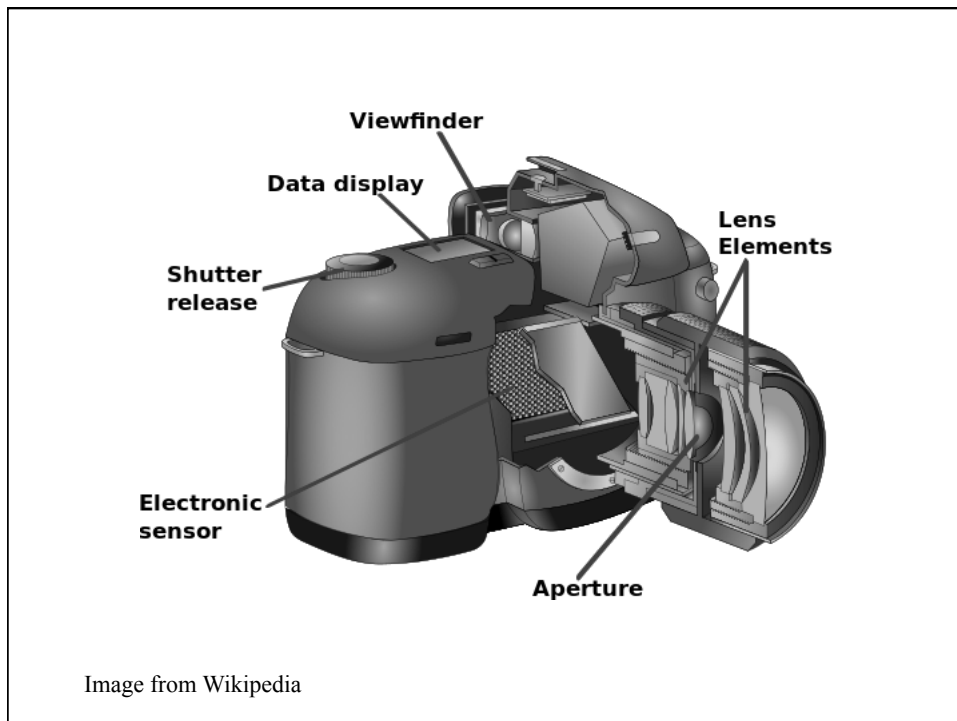
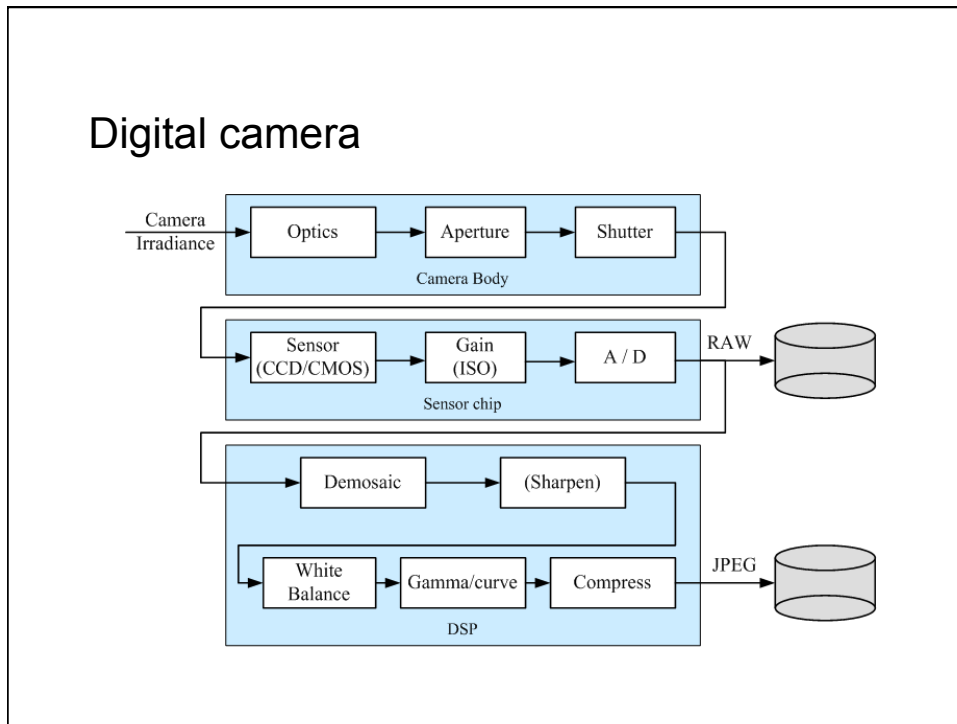

- Three concepts from film-based cameras:
 - Aperture
 - Shutter Speed
 - ISO: film density

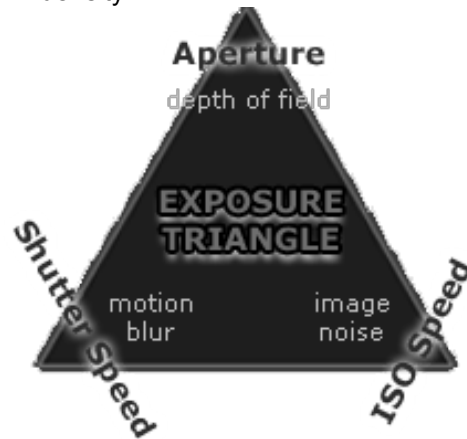

Image from: <http://www.cambridgeincolour.com>

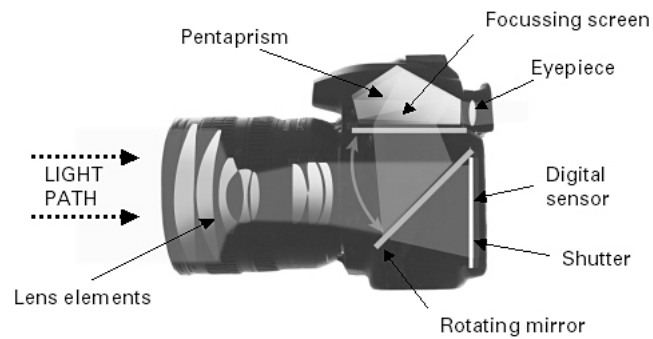
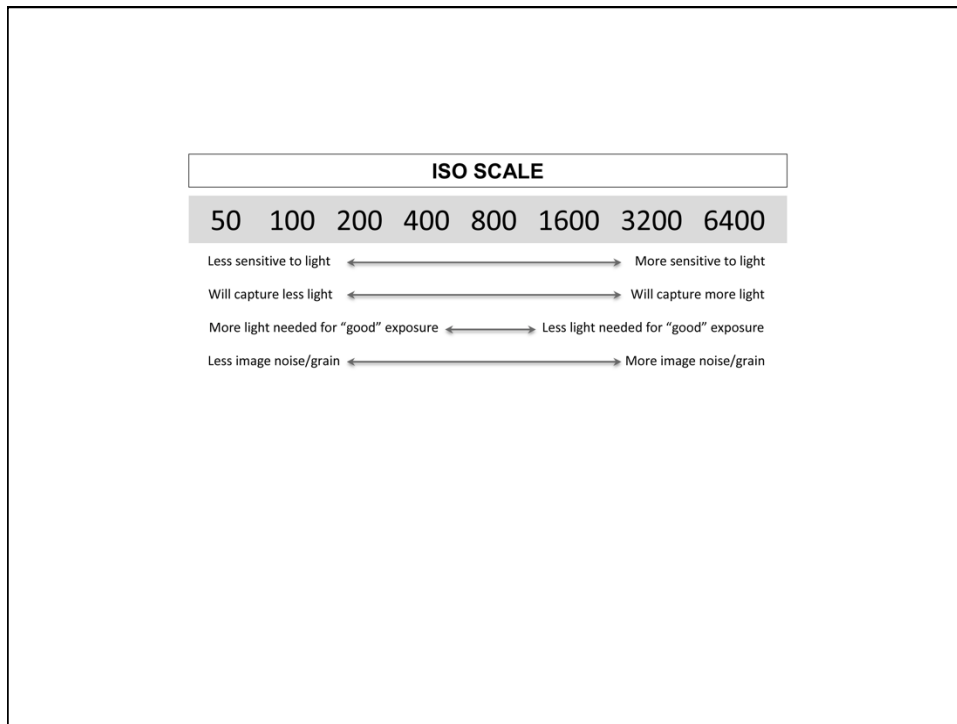

Image from <http://www.jiscdigitalmedia.ac.uk>



- Three concepts from film-based cameras:
 - Aperture
 - Shutter Speed
 - ISO: film density

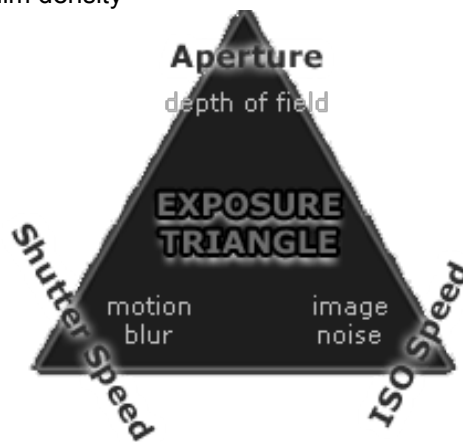

Image from: <http://www.cambridgeincolour.com>

- Several Parameters for a Digital camera
 - Mechanical and/or Electronic shutter
 - Sampling pitch: the physical spacing between adjacent sensors (typically in μm)
 - Small sampling pitch -> higher sampling density -> higher resolution. But also implies smaller area per sensor -> less light sensitivity + more noise
 - Fill Factor: the active sensing area size as a fraction of the available sensing area
 - Chip Size: larger chip size is preferred since each sensor can be more photo-sensitive, however more expensive.

- Analog gain: sensed signal is amplified
 - Automatic gain control: amplification is a function of the exposure
 - Manual setting: digital ISO setting
 - Higher ISO: more gain which implies better under low light condition.
 - However more noise (amplifies the sensor noise)
- ADC resolution: Analog to digital conversion: how many bits are used to quantize the received signal at each sensor unit
 - 16 bits for RAW format
 - 8 bits for JPEG
 - Less bits: quantization error
 - More bits increases the noise (effect of input noise)

Color cameras

- Two types of color cameras
 - Single CCD array
 - in front of each CCD element is a filter - red, green or blue
 - color values at each pixel are obtained by hardware interpolation
 - subject to artifacts
 - lower intensity quality than a monochromatic camera
 - similar to human vision
 - 3 CCD arrays packed together, each sensitive to different wavelengths of light

3 CCD cameras

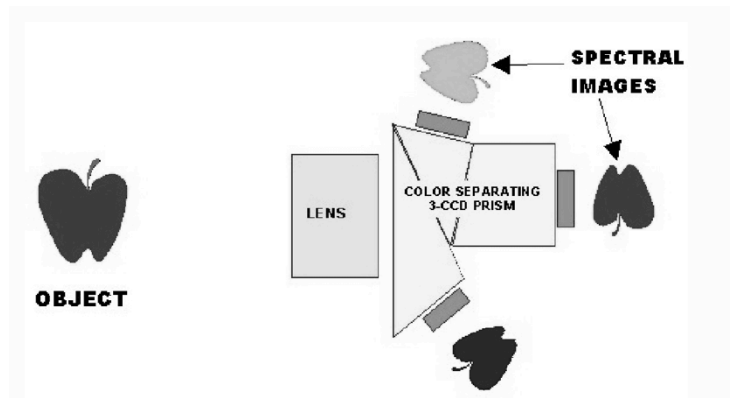

Sources

- Computer Vision a Modern approach: 1.1, 1.2,1.4
- Burger and Burge, Digital Image Processing Ch 2
- Wandell, Foundations of Vision
- Slides by:
 - D. Forsyth @UC Berkeley
 - J. Ponce @UIUC
 - L. Davis @UMD