

Section 1.8 Functions

Definition: Let A and B be sets. A function (mapping, map) f from A to B , denoted $f: A \rightarrow B$, is a subset of $A \times B$ such that

$$\forall x[x \in A \rightarrow \exists y[y \in B \wedge \langle x, y \rangle \in f]]$$

and

$$[\langle x, y_1 \rangle \in f \wedge \langle x, y_2 \rangle \in f] \rightarrow y_1 = y_2$$

Note: f associates with each x in A one and only one y in B .

A is called the *domain* and

B is called the *codomain*.

If $f(x) = y$

- y is called the *image* of x under f
- x is called a *preimage* of y

(note there may be more than one preimage of y but there is only one image of x).

The *range* of f is the set of all images of points in A under f . We denote it by $f(A)$.

If S is a subset of A then

$$f(S) = \{f(s) \mid s \text{ in } S\}.$$

Example:

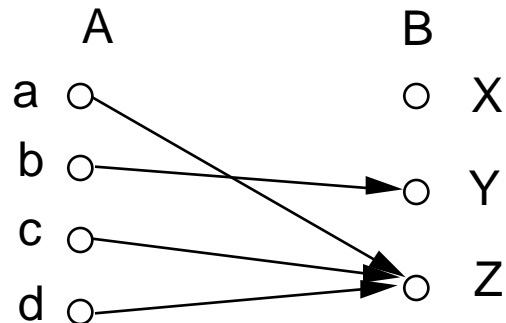

- $f(a) = Z$
- the image of d is Z
- the domain of f is $A = \{a, b, c, d\}$
- the codomain is $B = \{X, Y, Z\}$
- $f(A) = \{Y, Z\}$
- the preimage of Y is b
- the preimages of Z are a, c and d
- $f(\{c, d\}) = \{Z\}$

Injections, Surjections and Bijections

Let f be a function from A to B .

Definition: f is *one-to-one* (denoted 1-1) or *injective* if preimages are unique.

Note: this means that if $a \neq b$ then $f(a) \neq f(b)$.

Definition: f is *onto* or *surjective* if every y in B has a preimage.

Note: this means that for every y in B there must be an x in A such that $f(x) = y$.

Definition: f is *bijective* if it is surjective and injective (one-to-one and onto).

Examples:

The previous Example function is neither an injection nor a surjection. Hence it is not a bijection.

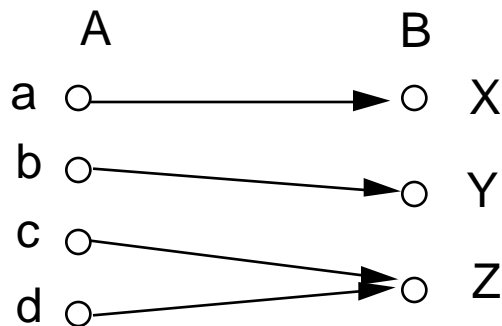

Surjection but not an injection

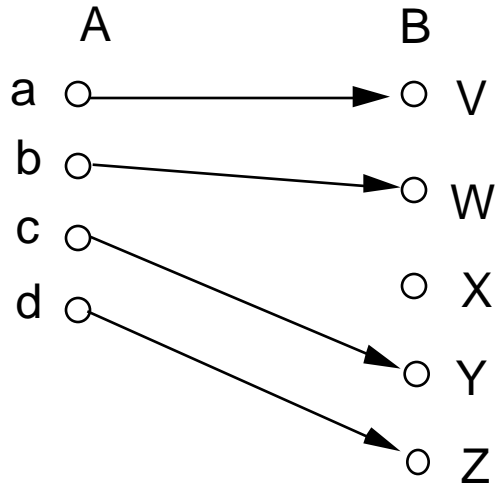

Injection but not a surjection

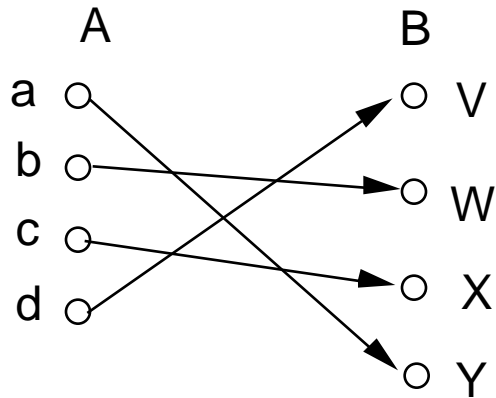

Surjection and an injection, hence a bijection

Note: Whenever there is a bijection from A to B, the two sets must have the same number of elements or

the same *cardinality*.

That will become our *definition*, especially for infinite sets.

Examples:

Let $A = B = \mathbb{R}$, the reals. Determine which are injections, surjections, bijections:

- $f(x) = x$,
 - $f(x) = x^2$,
 - $f(x) = x^3$,
 - $f(x) = x + \sin(x)$,
 - $f(x) = |x|$
-

Let E be the set of even integers $\{0, 2, 4, 6, \dots\}$.

Then there is a bijection f from N to E , the even nonnegative integers, defined by

$$f(x) = 2x.$$

Hence, the set of even integers has the same cardinality as the set of natural numbers.

OH, NO! IT CAN'T BE.... E IS ONLY HALF AS BIG!!!

Sorry! It gets worse before it gets better.

Inverse Functions

Definition: Let f be a bijection from A to B . Then the *inverse* of f , denoted f^{-1} , is the function from B to A defined as

$$f^{-1}(y) = x \text{ iff } f(x) = y$$

Example:

Let f be defined by the diagram:

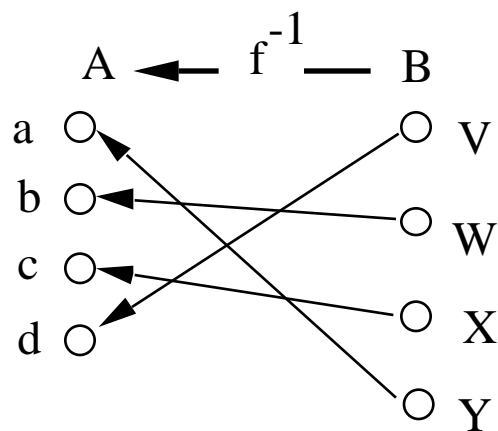
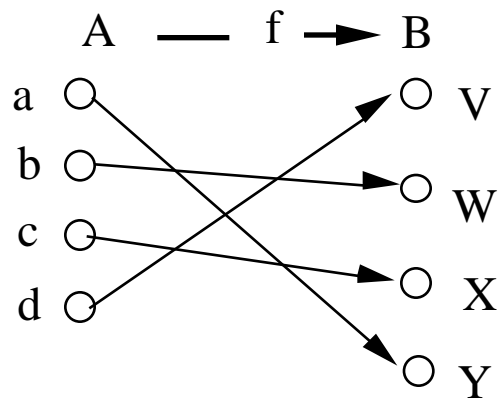

Note: No inverse exists unless f is a bijection.

Definition: Let S be a subset of B . Then

$$f^{-1}(S) = \{x \mid f(x) \in S\}$$

Note: f need not be a bijection for this definition to hold.

Example:

Let f be the following function:

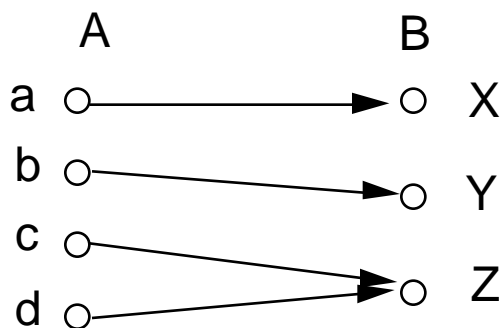

$$f^{-1}(\{Z\}) = \{c, d\}$$

$$f^{-1}(\{X, Y\}) = \{a, b\}$$

Composition

Definition: Let $f: B \rightarrow C$, $g: A \rightarrow B$. The *composition of f with g* , denoted $f \circ g$, is the function from A to C defined by

$$f \circ g(x) = f(g(x))$$

Examples:

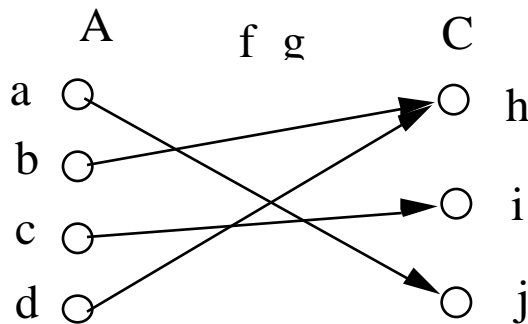
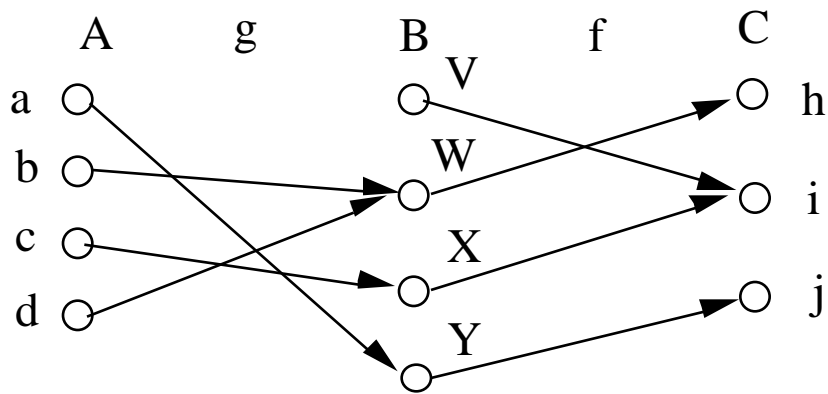

If $f(x) = x^2$ and $g(x) = 2x + 1$, then $f(g(x)) = (2x+1)^2$ and $g(f(x)) = 2x^2 + 1$

Definition: The

floor function,

denoted $f(x) = \lfloor x \rfloor$ or $f(x) = \text{floor}(x)$, is the largest integer less than or equal to x .

The

ceiling function,

denoted $f(x) = \lceil x \rceil$ or $f(x) = \text{ceiling}(x)$, is the smallest integer greater than or equal to x .

Examples: $\lfloor 3.5 \rfloor = 3$, $\lceil 3.5 \rceil = 4$.

Note: the floor function is equivalent to truncation for positive numbers.

Example:

Suppose $f: B \rightarrow C$, $g: A \rightarrow B$ and $f \circ g$ is injective.

What can we say about f and g ?

- We know that if $a \neq b$ then $f(g(a)) \neq f(g(b))$ since the composition is injective.

- Since f is a function, it cannot be the case that $g(a) = g(b)$ since then f would have two different images for the same point.

- Hence, $g(a) \neq g(b)$

It follows that g must be an injection.

However, f need not be an injection (you show).

